



turn to the experts 



39L Series

Central Station Air Handlers

Nominal: 2,000-20,000 CFM



39L Series



Compact, fully-assembled air-handlers combine versatility with economical, dependable performance.

Features & benefits

Dependable performance

The 39L is built to last. Sturdy milled galvanized steel formed panels ensure durability under all climate conditions and operational wear. Double-skinned access doors increase construction stability and provide low-frequency sound attenuation. Durable double-walled drain pan protects insulation from damage and controls moisture.

Internally mounted motors and drives are contained in a moving air environment where only cool, filtered, dehumidified air circulates. The result is longer motor bearing and belt life with less servicing. In addition, factory-installed motors and drives are protected from shipping damage and vandalism. All factory-installed drives are aligned at the factory. And, factory-installed internally mounted motors and drives save installation time and expense.

Carrier precision balances all 39L fan wheels to limit vibration and eliminate abnormal stress on bearings and other vital unit components. Rugged bearings are selected at a minimum 200,000 hours average bearing life at maximum allowable operating conditions. Bearings are securely fastened to a solid steel fan shaft with a split collet and clamp locking device. Field-proven bearings and fan shaft assure that vibration is controlled within narrowly prescribed limits.

Units are designed to handle dehumidification operation at face velocities up to 550 fpm without moisture carryover.

Economical

Carrier's 39L air-handlers are designed to save your money. The units are shipped fully-assembled with a single fan wheel and a single straight shot to the ductwork.

The small footprint is easier to rig and ensures economical use of building space.

High efficiency fan minimizes air turbulence and avoids surging and unbalanced operation, cutting operating expenses.

Hinged access doors on most accessories facilitate service and maintenance, saving time and money.

Flexibility

Carrier offers a wide selection of coils for your 39L application. With the help of the Carrier Electronic Catalog you can mix-match combinations of coils to meet your application needs.

Chilled water coils

The coil headers are constructed from schedule 40 steel pipe and are precisely sized to minimize water pressure loss. The coils are manufactured of 1/2-in. OD copper tubes, aluminum or copper fins (either 8- or 14-fins per inch), and galvanized steel coil casings. They feature Carrier's exclusive Opti-Fin® design for most efficient heat transfer.

Direct-expansion coils

Carrier's direct expansion coils offer the advantage of design flexibility and total economy...plus optimization of coil performance. Coils are available in 4, 6 row with 8 or 14 fins (aluminum or copper) per inch on 1/2-in. OD copper tubes. Choose from 2 or more circuitings on each coil surface for maximum thermal performance with minimum refrigerant pressure drop. Liquid and suction connections are always on the same end, regardless of circuiting, and may be specified for either right-or left-hand connections.

Model number nomenclature

1	2	3	4	5	6	7	8	9	10	11	12	13	14	15	16	17	18	19	20	21	22	Digit Number
39L	A	08	-	4/14	W	-	R	-	TF	-	10	P	F	Standard Unit								
39L	D	08	-	4/14	W	-	R	-	UF	-	10	P	F	Standard Unit								

39L - Light Commercial Air-Handler

Unit Model
 A - Horizontal Draw Through
 D - Vertical Draw Through

Unit Size
 06, 08, 10, 12, 15, 18, 21, 25, 31, 35

Coil Row/Fin
 4/8, 4/14, 6/8, 6/14

Coil Type
 W - Chilled Water Coil
 X - Direct Expansion Coil

Coil Circuit
 F - Full Circuit
 H - Half Circuit

Casing
 P - Painted Galvanized Steel

Insulation
 15 - 15 MM Thick

Fan Discharge
 TF, UF, UR - For Unit Model A
 UF, TF - For Unit Model D

Hand
 R - Right Hand Coil
 L - Left Hand Coil

39LA (Cooling)

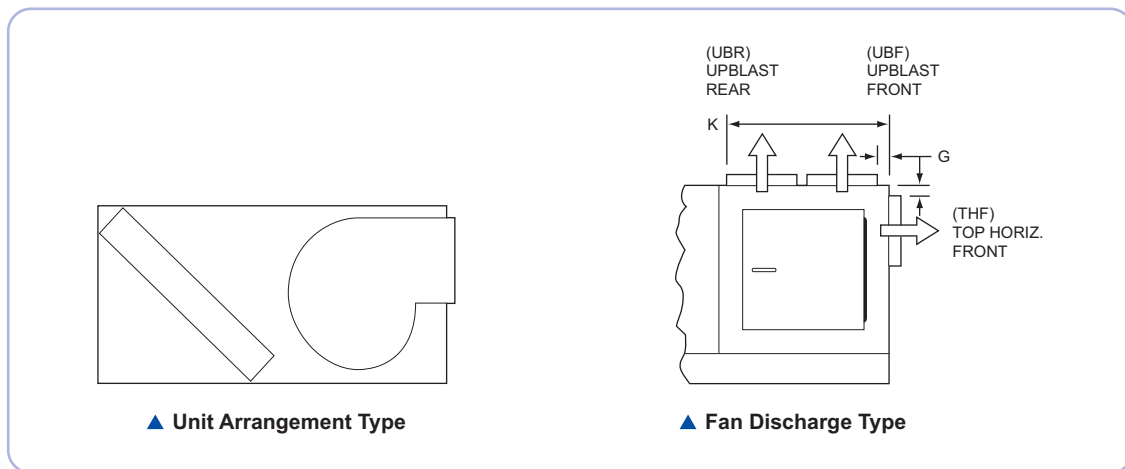

39LD (Cooling)

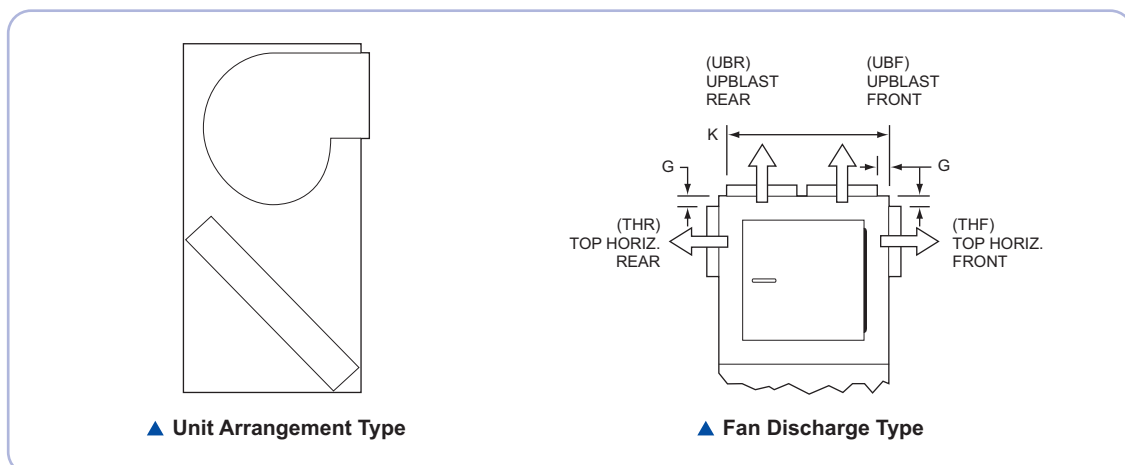

Physical data (Chilled water coil)

Description		Light Commercial Air Handling Unit										
Model		39LA, 39LD										
		06	08	10	12	15	18	21	25	31	35	
Chilled Water Coil	Nominal Performance* (1,000 Btu/h)	86.10	120.30	155.30	190.90	254.60	302.40	388.30	449.40	576.20	675.30	
Face Area	sq. ft.	5.90	7.90	9.54	11.20	14.90	17.70	21.60	25**	30.9**	35.5**	
Number of Tube/Face		20	24	24	24	32	38	38	22/22	22/24	24/24	
Finned Tube Length		in.	34.00	37.90	45.80	53.70	53.70	53.70	65.50	65.50	77.30	85.20
Connections	Coil Connection	in. MPT	1 1/2		2 1/2							
	Drain Connection	in. MPT	1 1/2									
Fans	Nominal Capacity at 500 fpm	CFM	2,950	3,950	4,770	5,600	7,450	8,850	10,800	12,500	15,450	17,750
	Wheel Diameter	in.	12	12	15	15	18	18	18	20	25	25
	Fan Shaft Diameter	mm.	25	25	25	25	25	25	25	35	45	45
Field Supplied	Air Filters	No...Size (in.)	2...20x20x2	2...20x25x2	2...16x25x2	3...20x25x2	6...16x20x2	3...16x20x2	3...16x25x2	2...16x20x2	4...16x20x2	3...16x20x2
					1...20x25x2			3...20x20x2	3...20x25x2	2...16x25x2	4...16x25x2	9...16x25x2
										2...20x20x2	1...20x20x2	
Motors	Motor Type		TEFC-Totally Enclosed Fan Cooled									
	Motor Horsepower	HP	Depends on Air Flow and Static Pressure									
	Nominal Motor Size	HP	2.0	2.0	3.0	3.0	5.0	7.5	10.0	15.0	15.0	20.0
	Motor Shaft Diameter	mm.	24.0	24.0	28.0	28.0	28.0	38.0	38.0	42.0	42.0	42.0
	Motor Full Load Amp	Amp	3.8	3.8	5.2	5.2	8.3	12.0	15.2	21.6	21.6	28.3
	Approximate Motor Weight	kgs	24.5	24.5	31.0	31.0	42.0	67.0	78.0	122.0	122.0	144.0
	Electrical Supply	V/Ph/Hz	380/3/50									

* Nominal performance are based on 45°F entering water, 10°F rise and 80/67 DB/WB entering air temp, 4R/14°F cooling coil.
 ** 39LA and 39LD units have 2 coils.

Note: For more details in Performance Data, supplied with computer selection, please contact your local area sales person.

Approximate unit weight

Model		39LA, 39LD										
		06	08	10	12	15	18	21	25	31	35	
Unit Type - Less Coil and Motor	39LA Less Coil and Motor	kg	118	186	213	245	281	315	336	372	431	458
	39LD Less Coil and Motor	kg	146	214	245	282	323	362	386	428	495	526
Chilled Water Coil Weight Dry Coil*	4-row	kg	41	48	54	67	87	97	123	137	170	195
	6-row	kg	47	61	69	86	116	133	162	180	223	256
Chilled Water Coil Volume	4-row	litre	13.2	17.0	19.7	21.2	27.6	32.2	39.4	45.4	53.7	61.7
	6-row	litre	17.8	22.7	25.7	29.1	38.2	44.3	53.7	61.7	76.1	87.4
Approximate Motor Weight		HP	1.0	2.0	3.0	5.0	7.5	10.0	15.0	20.0	25.0	30.0
		kgs	14.0	24.5	31.0	42.0	67.0	78.0	122.0	144.0	185.0	182.0

* Coils are 1/2 in. OD 14 Aluminium fins per inch on copper tubes, coil weight excluded water weight.

Chilled water coil connection position and diameter

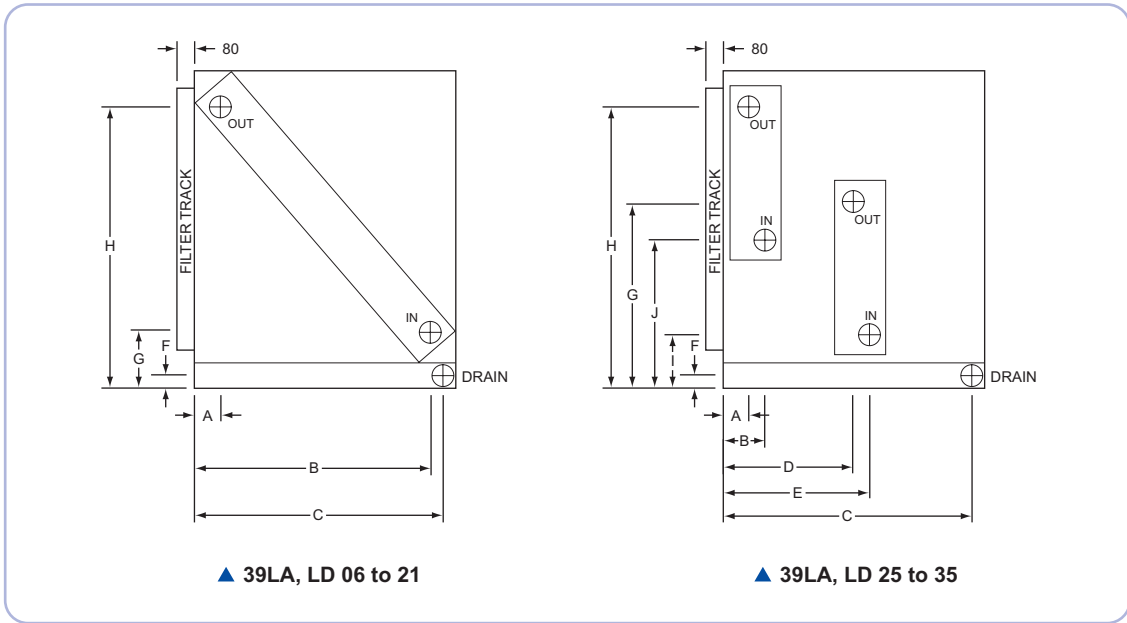

39L Unit Size	Dimensions (mm.)									
	A	B	C	D	E	F	G	H	I	J
06	100	510	560	-	-	37	230	550	-	-
08	100	610	645	-	-	37	235	645	-	-
10	100	610	645	-	-	37	235	645	-	-
12	100	610	645	-	-	37	235	645	-	-
15	100	785	840	-	-	37	235	815	-	-
18	100	915	945	-	-	37	235	955	-	-
21	100	915	945	-	-	37	235	955	-	-
25	100	160	640	525	615	37	815	1250	165	600
31	100	185	640	530	625	37	870	1250	165	600
35	100	185	640	535	625	37	870	1350	165	600

Service area

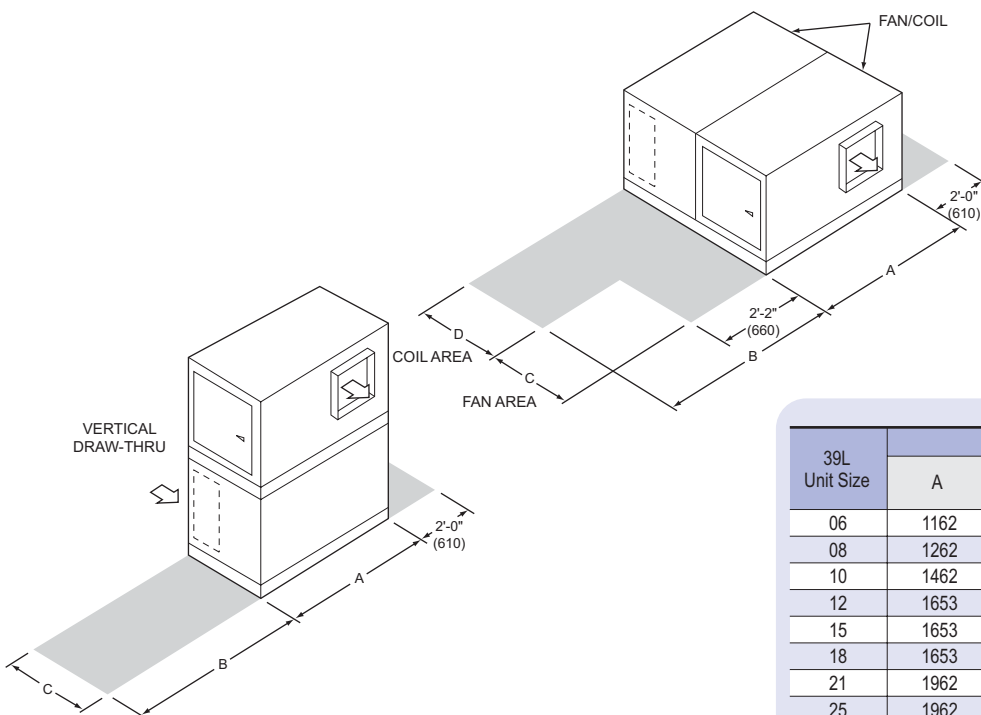

39L Unit Size	Dimensions (mm.)			
	A	B	C	D 39LA
06	1162	1159	640	600
08	1262	1259	740	700
10	1462	1459	740	700
12	1653	1659	740	700
15	1653	1659	940	900
18	1653	1659	1040	1000
21	1962	1959	1040	1000
25	1962	1959	1240	700
31	2262	2259	1240	700
35	2462	2459	1340	700

Fan performance

Model	Coil Area sq. ft.	Vel. FPM	CFM	Total Static Pressure (in. wg.)																							
				0.6		0.8		1.0		1.2		1.4		1.6		1.8		2.0		2.2		2.4					
				RPM	BHP	RPM	BHP	RPM	BHP	RPM	BHP	RPM	BHP	RPM	BHP	RPM	BHP	RPM	BHP	RPM	BHP	RPM	BHP	RPM	BHP		
06	5.90	350	2065	621	0.35	716	0.44	806	0.54	887	0.64	963	0.75	1035	0.87	1101	0.99	1163	1.11	1224	1.25	1281	1.38				
				626	0.44	715	0.54	801	0.64	881	0.75	956	0.86	1026	0.98	1092	1.10	1154	1.23	1214	1.37	1272	1.50				
				636	0.54	719	0.64	800	0.75	877	0.87	950	0.99	1019	1.11	1084	1.25	1146	1.38	1205	1.51	1263	1.66				
				651	0.66	728	0.78	804	0.90	877	1.02	947	1.15	1014	1.27	1078	1.41	1139	1.55	1198	1.69	1254	1.85				
				671	0.80	741	0.92	812	1.06	881	1.18	948	1.33	1013	1.46	1075	1.61	1134	1.74	1192	1.90	1247	2.05				
08	7.90	350	2765	641	0.58	722	0.68	801	0.80	877	0.92	948	1.05	1017	1.18	1082	1.31	1143	1.43	1202	1.58	1259	1.73				
				665	0.76	737	0.87	809	1.01	880	1.14	947	1.27	1013	1.41	1076	1.54	1135	1.69	1193	1.84	1249	1.98				
				695	0.98	760	1.11	825	1.25	890	1.38	953	1.53	1015	1.72	1075	1.84	1131	1.98	1188	2.14	1242	2.31				
				731	1.23	789	1.38	848	1.53	907	1.69	966	1.84	1023	2.00	1079	2.16	1133	2.32	1187	2.49	1240	2.67				
				771	1.55	823	1.70	877	1.86	931	2.04	984	2.20	1038	2.37	1090	2.55	1141	2.72	1192	2.90	1242	3.08				
10	9.54	350	3335	518	0.59	592	0.75	662	0.91	728	1.10	791	1.29	850	1.47	907	1.68	960	1.88	1012	2.08	1062	2.29				
				529	0.74	597	0.90	662	1.07	725	1.27	785	1.47	842	1.68	896	1.89	948	2.10	998	2.33	1047	2.56				
				544	0.92	607	1.09	668	1.27	727	1.47	783	1.68	838	1.90	890	2.13	940	2.36	989	2.59	1036	2.84				
				563	1.14	621	1.31	678	1.50	733	1.72	786	1.93	838	2.16	888	2.40	936	2.64	983	2.88	1029	3.15				
				584	1.41	638	1.58	691	1.78	743	2.00	794	2.23	843	2.45	890	2.71	936	2.95	981	3.22	1026	3.49				
12	11.20	350	3920	532	0.78	598	0.94	663	1.11	725	1.31	784	1.51	840	1.72	895	1.94	946	2.16	996	2.39	1045	2.61				
				551	1.01	612	1.17	671	1.37	729	1.57	784	1.77	837	2.00	889	2.23	938	2.47	986	2.71	1033	2.95				
				574	1.29	630	1.46	685	1.66	738	1.86	790	2.09	840	2.32	889	2.56	936	2.82	982	3.07	1027	3.34				
				601	1.64	652	1.82	703	2.02	753	2.24	801	2.47	848	2.71	894	2.96	938	3.22	982	3.49	1025	3.77				
				631	2.05	678	2.24	725	2.45	772	2.68	817	2.92	861	3.18	904	3.43	946	3.70	988	3.97	1029	4.26				
15	14.90	350	5215	447	0.90	508	1.11	567	1.35	622	1.60	674	1.84	723	2.10	769	2.37	814	2.64	854	2.92	894	3.20				
				459	1.13	514	1.35	569	1.61	622	1.88	671	2.14	719	2.43	764	2.71	808	3.00	848	3.30	888	3.61				
				475	1.39	525	1.65	576	1.92	625	2.21	672	2.49	718	2.80	762	3.10	803	3.40	844	3.73	883	4.06				
				494	1.72	541	2.00	587	2.29	632	2.59	677	2.90	720	3.22	762	3.55	800	3.90	841	4.21	880	4.56				
				517	2.10	559	2.40	602	2.71	644	3.03	685	3.36	726	3.70	766	4.05	807	4.40	848	4.76	889	5.12				

Fan performance

Model	Coil Area sq. ft.	Vel. FPM	CFM	Total Static Pressure (in. wg.)																							
				0.6		0.8		1.0		1.2		1.4		1.6		1.8		2.0		2.2		2.4					
				RPM	BHP	RPM	BHP	RPM	BHP	RPM	BHP	RPM	BHP	RPM	BHP	RPM	BHP	RPM	BHP	RPM	BHP	RPM	BHP	RPM	BHP		
18	17.70	350	6195	463	1.21	517	1.45	571	1.70	622	1.97	671	2.25	718	2.53	763	2.83	805	3.12	847	3.43	886	3.74				
		400	7080	484	1.55	533	1.82	581	2.10	628	2.39	674	2.69	718	3.00	761	3.32	802	3.63	842	3.97	881	4.30				
		450	7965	510	1.98	553	2.27	597	2.57	640	2.88	682	3.22	724	3.55	764	3.89	803	4.22	841	4.58	879	4.95				
		500	8850	538	2.49	577	2.80	617	3.14	656	3.47	695	3.82	734	4.18	772	4.54	808	4.91	844	5.28	880	5.67				
		550	9735	569	3.10	605	3.45	641	3.79	677	4.16	713	4.53	748	4.91	784	5.29	819	5.15	852	6.09	886	6.50				
21	21.60	350	7560	493	2.04	528	2.24	563	2.45	599	2.69	635	2.96	673	3.26	713	3.58	753	3.93	794	4.33	836	4.75				
		400	8640	534	2.83	566	3.06	597	3.30	627	3.54	658	3.81	689	4.09	722	4.38	754	4.71	788	5.07	823	5.44				
		450	9720	576	3.83	606	4.09	635	4.34	662	4.61	690	4.88	717	5.16	744	5.46	772	5.76	800	6.10	829	6.46				
		500	10800	619	5.04	648	5.34	675	5.63	701	5.91	726	6.21	751	6.50	775	6.81	799	7.12	824	7.45	849	7.80				
		550	11880	661	6.46	691	6.82	717	7.16	742	7.48	765	7.79	788	8.11	811	8.43	832	8.75	855	9.09	877	9.45				
25	25.00	350	8750	432	2.05	469	2.32	506	2.61	544	2.92	581	3.26	619	3.61	657	3.99	694	4.38	731	4.81	768	5.25				
		400	10000	463	2.79	496	3.08	529	3.40	562	3.73	594	4.06	627	4.42	660	4.81	692	5.20	725	5.62	758	6.06				
		450	11250	495	3.69	526	4.03	556	4.38	586	4.73	615	5.09	644	5.47	673	5.84	701	6.25	730	6.68	760	7.10				
		500	12500	527	4.77	558	5.17	586	5.56	614	5.94	640	6.33	667	6.73	693	7.13	718	7.55	744	7.98	770	8.42				
		550	13750	560	6.05	590	6.51	618	6.96	644	7.39	669	7.80	693	8.23	717	8.66	740	9.09	764	9.54	788	10.00				
31	30.90	350	10815	294	1.89	333	2.32	372	2.79	409	3.30	444	3.82	478	4.38	511	4.97	542	5.58	572	6.21	601	6.86				
		400	12360	303	2.41	338	2.87	373	3.35	407	3.89	440	4.44	472	5.01	503	5.63	533	6.25	562	6.90	590	7.59				
		450	13905	314	3.03	347	3.53	379	4.05	410	4.60	441	5.17	471	5.78	500	6.42	528	7.05	555	7.73	582	8.43				
		500	15450	327	3.78	357	4.32	387	4.88	416	5.45	444	6.06	472	6.69	499	7.35	526	8.02	552	8.71	578	9.44				
		550	16995	341	4.66	370	5.24	398	5.84	425	6.46	451	7.09	477	7.75	502	8.43	527	9.13	552	9.85	576	10.59				
35	35.50	350	12425	303	2.43	339	2.88	374	3.38	407	3.91	440	4.46	472	5.05	503	5.65	533	6.29	562	6.94	590	7.61				
		400	14200	316	3.16	349	3.66	380	4.20	411	4.75	441	5.34	471	5.94	499	6.58	527	7.23	554	7.91	581	8.62				
		450	15975	332	4.06	361	4.61	390	5.19	419	5.78	446	6.39	474	7.04	500	7.69	526	8.36	552	9.08	577	9.81				
		500	17750	349	5.13	376	5.75	403	6.37	430	7.01	455	7.67	480	8.44	505	9.03	529	9.73	553	10.47	576	11.22				
		550	19525	366	6.41	393	7.08	418	7.76	443	8.45	466	9.14	490	9.87	513	10.59	535	11.33	557	12.09	580	12.88				

Unit dimensions

39LA

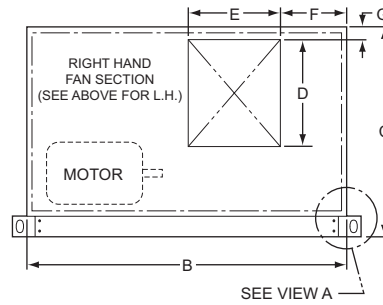
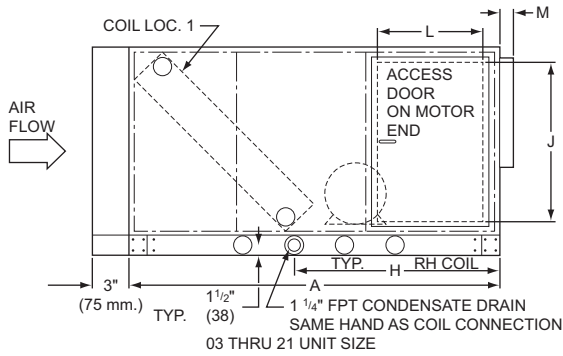
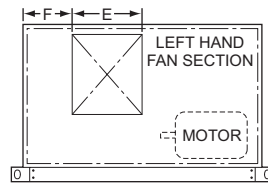
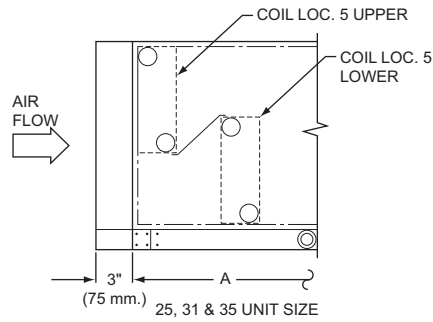
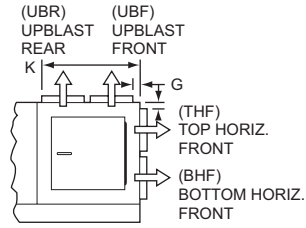
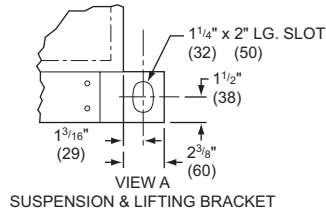

Unit 39LA	Dimensions (mm.)											
	A	B	C	D	E	F	G	H	J	K	L	M
06	1,240	1,160	715	344	395	260	60	697	560	580	445	35
08	1,440	1,260	815	344	395	273	87	800	655	653	443	35
10	1,440	1,460	815	405	470	302	59	800	649	680	654	50
12	1,440	1,660	815	405	470	353	60	800	655	680	443	50
15	1,840	1,660	1,015	483	559	300	89	1,000	860	851	445	60
18	2,040	1,660	1,115	513	559	312	95	1,107	960	921	445	60
21	2,040	1,960	1,115	565	565	508	120	1,107	960	920	445	60
25	1,940	1,960	1,315	640	640	450	184	1,100	1,154	1,050	444	50
31	1,940	2,240	1,415	800	800	520	45	1,100	1,252	1,290	444	60
35	2,040	2,440	1,415	805	800	670	40	1,100	1,252	1,295	444	60

Unit dimensions

39LD

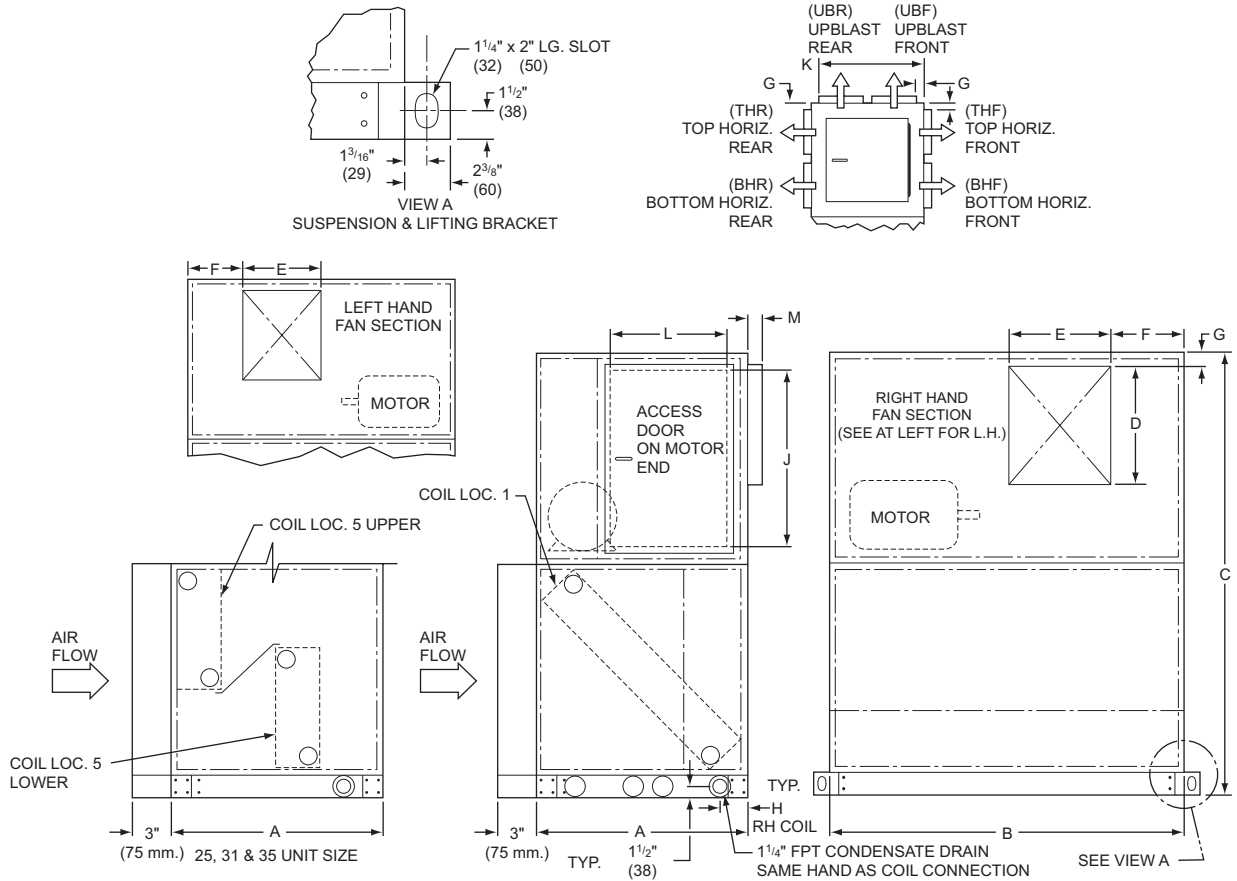

Unit 39LD	Dimensions (mm.)											
	A	B	C	D	E	F	G	H	J	K	L	M
06	640	1,160	1,345	344	395	256	60	100	560	580	445	35
08	740	1,260	1,545	344	395	273	87	103	649	653	654	35
10	740	1,460	1,555	405	470	302	59	103	649	680	654	50
12	740	1,660	1,555	405	470	353	60	103	649	680	654	50
15	940	1,660	1,945	483	559	300	89	103	860	851	445	60
18	1,040	1,660	2,145	483	559	312	119	100	960	921	445	60
21	1,040	1,960	2,145	565	565	508	120	100	960	920	445	60
25	1,240	1,960	2,545	640	640	449	110	620	1,154	1,125	444	50
31	1,240	2,240	2,645	800	800	519	45	620	1,252	1,190	444	60
35	1,340	2,440	2,745	800	800	676	40	843	1,252	1,295	444	60

Physical data

Direct Expansion Coil Circuiting Data

Unit Size		39LA, 39LD														
		06			08			10			12		15		18	
Circuiting Type		Qtr	Half	Full	Qtr	Half	Full	Qtr	Half	Full	Half	Full	Half	Full	Half	Full
Face Area	sq. ft.	5.90			7.91			9.58			11.25		14.91		17.81	
Tube Face		20			24			24			24		32		38	
Tube Length	in.	34.1			37.9			45.8			53.7		53.7		53.7	
Number of Circuits		-	10	20	-	12	24	-	12	24	12	24	16	32	19	38
Number of TXV's		-	2	2	-	2	2	-	2	2	2	2	2	4*	2	4*
Number of Circuits/TXV		-	5	10	-	6	12	-	6	12	6	12	8	8	9-10	9-10
Suction Connections Diam	in. OD	-	1 1/8	1 3/8	-	1 1/8	1 5/8	-	1 1/8	1 5/8	1 1/8	1 5/8	1 3/8	1 3/8	1 3/8	1 3/8
Distributor Connections Diam	in. OD	-	7/8	1 1/8	-	7/8	1 5/8	-	7/8	1 5/8	7/8	1 1/8	1 1/8	1 1/8	1 1/8	1 1/8
Circuit Equivalent Length	ft.	-	32	-	-	34	18	-	40	20	45	23	45	23	45	23
Distributor Tube Length	4-Row Face Split in.	-	11	-	-	13	15	-	13	15	13	15	15	16	16	16
	4-Row Row Split in.	-	16	-	-	18	18	-	18	18	18	18	26	16	28	16
Circuit Equivalent Length	ft.	-	47	24	-	51	26	-	59	30	67	34	67	34	67	34
Distributor Tube Length	6-Row Face Split in.	-	11	13	-	13	15	-	13	15	13	15	15	16	16	18
	6-Row Row Split in.	-	16	18	-	18	21	-	18	21	18	21	23	16	28	18

Direct Expansion Coil Circuiting Data

Unit Size		39LA, 39LD														
		21			25			31			35					
Circuiting Type		Half	Full	Double	Half	Full	Double	Half	Full	Double	Half	Full	Double			
Face Area	sq. ft.	21.40			24.82			30.74			35.40					
Tube Face		38			22U-22L			22U-24L			24U-24L					
Tube Length	in.	65.5			65.5			77.3			85.2					
Number of Circuits		19	38	-	22	44	88	23	46	92	24	48				
Number of TXV's		2	4*	-	U	L	U	L	U	L	U	L	U	L	U	L
Number of Circuits/TXV		9-10	9-10	-	5-6	5-6	11	11	11	11	5-6	6	11	12	11	12
Suction Connections Diam	in. OD	1 3/8	1 1/8	-	1 1/8	1 1/8	1 1/8	1 1/8	1 5/8	1 5/8	1 1/8	1 1/8	1 1/8	1 1/8	1 5/8	1 5/8
Distributor Connections Diam	in. OD	1 1/8	1 1/8	-	7/8	7/8	1 1/8	1 1/8	1 3/8	1 3/8	7/8	7/8	7/8	7/8	1 3/8	1 1/8
Circuit Equivalent Length	ft.	54	26	-	54	54	26	26	-	-	62	62	30	30	-	-
Distributor Tube Length	4-Row Face Split in.	16	16 3/4	-	12	12	15	15	-	-	12	13	15	15	-	-
	4-Row Row Split in.	28	16 3/4	-	21	21	23	23	-	-	21	18	23	23	-	-
Circuit Equivalent Length	ft.	81	40	-	-	-	40	40	-	-	-	-	46	46	-	-
Distributor Tube Length	6-Row Face Split in.	16	18 1/2	-	-	-	15	15	-	-	-	-	15	15	-	-
	6-Row Row Split in.	28	18 1/2	-	-	-	22	22	-	-	-	-	22	22	-	-

* May be field mainfolded for either face split or row split U - Upper L - Lower

Operating Charge - English

Unit Size 39LA, 39LD		06	08	10	12	15	18	21	25	31	35
Refrigerant		R-22 (lb)									
Rows	4	2-3	3-4	4-5	4-5	5-6	6-7	6-8	6-9	7-12	10-15
	6	2-4	5-6	5-6	6-8	8-10	9-11	11-13	11-16	14-20	17-26

Coil performance

Direct Expansion Coil Ratings

45°F Saturated Suction, 80°F DB, 67°F WB Entering Air

Unit Size	CFM	4 Row - 8 Fin				4 Row - 14 Fin				6 Row - 8 Fin				6 Row - 14 Fin			
		1,000 Btuh	Ldb (°F)	Lwb (°F)	Ckt	1,000 Btuh	Ldb (°F)	Lwb (°F)	Ckt	1,000 Btuh	Ldb (°F)	Lwb (°F)	Ckt	1,000 Btuh	Ldb (°F)	Lwb (°F)	Ckt
6	2,950	*	*	*	*	104.4	55.7	55.7	H	111.8	54.8	54.8	H	131.0	52.4	52.4	H
6	2,950	--	--	--	-	--	--	--	-	*	*	*	*	*	*	*	*
8	3,950	*	*	*	*	143.4	55.4	55.4	H	151.1	54.7	54.7	H	175.4	52.4	52.4	H
8	3,950	*	*	*	*	*	*	*	*	*	*	*	*	*	*	*	*
10	4,770	143.4	57.6	57.6	H	177.4	55.1	55.1	H	181.4	54.8	54.8	H	206.6	52.8	52.8	H
10	4,770	*	*	*	*	*	*	*	*	*	*	*	*	*	*	*	*
12	5,590	170.7	57.4	57.4	H	207.8	55.1	55.1	H	207.0	55.1	55.1	H	231.9	53.5	53.5	H
12	5,590	*	*	*	*	*	*	*	*	*	*	*	*	247.2	52.5	52.5	F
15	7,455	227.7	57.4	57.4	H	277.1	55.1	55.1	H	276.1	55.1	55.1	H	309.3	53.5	53.5	H
15	7,455	*	*	*	*	*	*	*	*	*	*	*	*	329.7	52.5	52.5	F
18	8,855	270.4	57.4	57.4	H	329.2	55.1	55.1	H	328.0	55.1	55.1	H	367.3	53.5	53.5	H
18	8,855	*	*	*	*	*	*	*	*	*	*	*	*	391.6	52.5	52.5	F
21	10,800	328.1	57.5	57.5	H	389.8	55.5	55.5	H	375.2	55.9	55.9	H	410.3	54.8	54.8	H
21	10,800	*	*	*	*	379.5	55.8	55.8	F	414.9	54.6	54.6	F	487.7	52.1	52.1	F
25	12,500	379.7	57.5	57.5	H	451.2	55.5	55.5	H	--	--	--	-	--	--	--	-
25	12,500	*	*	*	*	439.1	55.8	55.8	F	480.2	54.6	54.6	F	564.5	52.1	52.1	F
31	15,450	454.7	57.8	57.8	H	527.9	56.1	56.1	H	--	--	--	-	--	--	--	-
31	15,450	454.7	57.8	57.8	F	569.4	55.2	55.2	F	601.4	54.4	54.4	F	697.5	52.1	52.1	F
35	17,750	507.0	58.1	58.1	H	579.8	56.7	56.7	H	--	--	--	-	--	--	--	-
35	17,750	534.6	57.6	57.6	F	665.1	55.0	55.0	F	690.2	54.5	54.5	F	793.9	52.3	52.3	F

-- Not available.

* No available circuit within loading range.

Air friction data

Cooling Coil Air Friction (in. wg.)

Rows	Fins	Face Velocity (fpm)					
		300	400	500	550	600	700
4	8	<i>0.13</i>	<i>0.21</i>	<i>0.32</i>	<i>0.39</i>	<i>0.45</i>	<i>0.60</i>
		0.20	0.31	0.43	0.50	0.57	0.72
4	14	<i>0.20</i>	<i>0.33</i>	<i>0.49</i>	<i>0.57</i>	<i>0.67</i>	<i>0.87</i>
		0.27	0.43	0.60	0.70	0.80	1.02
6	8	<i>0.19</i>	<i>0.32</i>	<i>0.48</i>	<i>0.58</i>	<i>0.68</i>	<i>0.90</i>
		0.30	0.46	0.65	0.75	0.86	1.08
6	14	<i>0.30</i>	<i>0.50</i>	<i>0.73</i>	<i>0.86</i>	<i>1.00</i>	<i>1.31</i>
		0.40	0.64	0.91	1.05	1.21	1.53

Italic type indicates dry coil.

Filters Air Friction (in. wg.)

Filter Type		Velocity (fpm) Through Filter								
		250	300	350	400	450	500	550	600	650
Flat (2 in.)	Initial	0.03	0.04	0.05	0.07	0.09	0.10	0.13	0.15	0.18
	Final	0.50	0.50	0.50	0.50	0.50	0.50	0.50	0.50	0.50

Notes:

1. Filters are field supplied.
2. Do not exceed filter manufacturer's velocity limits when selecting filters.
3. Filters having cardboard type frames are usually not suitable for use in high velocity (flat) sections.

Guide specifications

Central Station Air-Handling Unit HVAC Guide Specifications - Section 15860 Size Range: 2,000-20,000 Nominal CFM Carrier Model Number: 39L

Part 1 - General

1.01 SYSTEM DESCRIPTION

- A. Indoor central station air-handling unit designed to provide air to a conditioned space as required to meet specified performance requirements for ventilation, heating, cooling, filtration and distribution. Unit shall be assembled for draw-thru application and shall be arranged to discharge conditioned air horizontally or vertically as shown on the contract drawings.
- B. Unit with a direct-expansion cooling coil can be used in a refrigerant circuit in conjunction with Air-Cooled Condensing Units or Split-System Heat Pump Outdoor Units.

1.02 DELIVERY, STORAGE AND HANDLING

- A. Unit shall be stored and handled in accordance with the unit manufacturer's instructions.

Part 2 - Products

2.02 EQUIPMENT

A. General:

Factory assembled, single-piece central station air-handler. Unit may consist of a fan and coil section with a factory-installed chilled water or direct-expansion coil, preheat or reheat coil, heating coil section, filter section, mixing box or combination mixing box and access section as indicated on the equipment schedules.

B. Unit Cabinet:

1. Unit panels shall be constructed of milled galvanized steel. Casing panels shall be removable for easy access to the unit.
2. Hinged access doors shall be double wall with 1.5 lb. dual density fiberglass between galvanized steel panels.
3. Insulation for casing panels on unit shall be with 3/8 inch minimum thickness dual density closed cell foam insulation with a density of not less than nominal 2 lb. per cubic foot.
4. Insulation shall be secured to casing with waterproof adhesive.
5. Condensate drain pans shall have double wall construction with threaded drain connection.

C. Fan Section:

1. Fan sections shall be constructed of galvanized steel and have a formed channel base for integral mounting of fan, motor and casing panels. Fan scroll, wheel, shaft and bearings are to be rigidly secured to the unit base.
2. Each unit shall have one fan wheel and scroll only. Fans shall be double width, double inlet type, with forward-curved blades. Wheels shall be bonderized steel painted with baked enamel, or galvanized steel.
3. Fan wheels shall be keyed to the shaft and shall be designed for continuous operation at the maximum rated fan speed and motor horsepower. Fan wheels and shafts shall be selected to operate at least 25% below the first critical speed, and shall be statically and dynamically balanced as an assembly.

4. Fan shafts shall be solid steel, turned, ground and polished.
5. Fan bearings shall be self-aligning pillow block type selected for an average life of 200,000 hours at design operation conditions;
6. Fan motor shall be mounted within the fan section casing on side rails having 2 adjusting screws. Motor shall be TEFC sized and electrical characteristics as shown on the equipment schedule.
7. Fan drive shall be designed for a 1.3 service factor. Belt drive shall be variable or fixed-pitch type.

D. Coil Sections:

1. All water and refrigerant coils shall be factory tested for leakage at 400 psig air pressure with coils submerged in water. After testing, direct-expansion coils shall be dehydrated and charged with dry air.
2. Chilled water coils shall be aluminum plate fins with belled collars and bonded to 1/2-in. minimum OD copper tubes by mechanical expansion. Coils shall have galvanized steel casings and steel headers with threaded connections. Working pressure shall be 300 psig at 200 °F. Coils shall be drainable and have nontrapping circuits. No turbulence promoting devices will be permitted inside the tubes. Headers shall have drain and vent connections.
3. Direct-expansion coils shall be aluminum plate fins with belled collars and bonded to 1/2-in. OD copper tubes by mechanical expansion. Coils shall be provided with pressure-type brass distributors with solder-type connections and shall have a minimum of 2 distributors. Coils for full face active or face split operation shall have intertwined circuits for equal loading on each circuit. Suction and discharge connections shall be on the same end. After testing, coils shall be dehydrated and charged with dry air.

E. Filter Sections:

1. Each filter section shall be designed and constructed to house the specific type of filter specified on the equipment schedule.
2. Flat filter sections shall accept filters of standard sizes. Sections shall include side access slide rails and hinged access door. Flat filter section to be arranged with minimum depth in direction of airflow.
3. Angle filter sections shall accept 2-in. filters arranged in horizontal V formation. Double walled hinged access doors shall be provided.

F. Special Features:

Certain standard features are not applicable when the features designated by * are specified. For assistance in amending the specifications, your local Carrier Sales Office should be contacted.

1. Unit Cabinet:

- a. Air-dry paint finish on exterior of unit.
- b. Stainless steel liner in drain pan.

2. Fan Section:

- a. High-efficiency motor.
- b. TEFC motor for variable speed drive.

3. Coil Section:

- a. Chilled water coil with copper plate fins.
- b. Direct expansion coil with copper plate fins.
- c. Hot water (U-bend) coil with copper plate fins.
- d. Steam distributing coil with copper fins.

บริษัท แคนเรีย (ประเทศไทย) จำกัด

ชั้น 14-15 อาคารเนชั่น ทาวเวอร์
1858/63-74 ถ.บางนา-ตราด กม. 4.5
บางนา กรุงเทพฯ 10260
โทร. 0-2751-4777 แฟกซ์: 0-2751-4778

Carrier (Thailand) Ltd.

14-15th Fl., Nation Tower,
1858/63-74 Bangna-Trad Road Km. 4.5,
Bangna,
Bangkok 10260 Thailand



YOUR CARRIER MAN :