



AIR-COOLED LIQUID CHILLER REVERSIBLE AIR-TO-WATER HEAT PUMP

PRO-DIALOG PLUS

AQUASNAP™



30RB/RQ 039S-160S

Refrigerant HFC-410A

Nominal cooling capacity 40-158 kW

Nominal heating capacity 41-159 kW

The new generation of Aquasnap Puron liquid chillers/air-to-water heat pumps was designed for commercial (air conditioning of offices, hotels etc.) or industrial (low-temperature process chillers etc.) applications.

Benefits:

- Standard unit with hydronic module including all necessary hydronic components, easy and fast installation to save time, space and money.
- Low operating sound with no intrusive low-frequency noise, creates a better working/living environment.
- Environment sound refrigerant HFC-410A of zero ozone depletion potential.
- Electronic expansion valve (EXV) utilization, several compressors connected in parallel lead to more economical operating cost.
- Exceptional endurance tests ensure superior reliability for minimizing chiller down-time.

Features

Easy and fast installation

- Integrated hydronic module
 - Centrifugal fixed speed water pump
 - Single or dual pump (as required) with operating time balancing and automatic changeover to the back-up pump if a fault develops
 - Water filter protecting the water pump against circulating debris
 - High-capacity membrane expansion tank ensures pressurization of the water circuit
 - Thermal insulation and frost protection down to -20 °C, using an electric resistance heater
- Physical features
 - The unit has a small footprint and a low height (1330 mm) allowing it to blend in with any architectural styles.
 - The unit is enclosed by easily removable panels, covering all components (except condensers and fans).

Features

- Simplified electrical connections
 - A single power supply point without neutral
 - Main disconnect switch with high trip capacity
 - Transformer for safe 24 V control circuit supply included
- Fast commissioning
 - Systematic factory operation test before shipment
 - Quick-test function for step-by-step verification of the instruments, electrical components and motors

Quiet operation

- Compressors
 - Low-noise scroll compressors with low vibration level
 - The compressor assembly is installed on an independent chassis and supported by anti-vibration mountings
 - Dynamic suction and discharge piping support, minimizing vibration transmission (Carrier patent)
- Condenser section
 - Vertical condenser coils
 - Protection grilles on anti-vibration mountings to protect the heat exchanger against possible shocks.
 - Low-noise latest-generation Flying Bird IV fans (Carrier patent) , made of a composite material are now even quieter and do not generate intrusive low-frequency noise
 - Rigid fan installation for reduced start-up noise (Carrier patent)

Economical operation

- Increased energy efficiency at part load
 - The refrigerant circuit includes several compressors connected in parallel. At part load, around 99% of the operating time, only the compressors that are absolutely necessary operate. At these conditions the compressors operating are more energy efficient, as they use the total condenser and evaporator capacity.
 - The electronic expansion device (EXV) allows operation at a lower condensing pressure (EER, COP and ESEER optimization).
 - Dynamic superheat management for better utilization of the evaporator heat exchange surface.
 - Defrost cycle optimization (30RQ)
- Reduced maintenance costs
 - Maintenance-free scroll compressors
 - Fast diagnosis of possible incidents and their history via the Pro-Dialog Plus control
 - HFC-410A refrigerant is easier to use than other refrigerant blends

Environmental care

- Ozone-friendly HFC-410A refrigerant
 - Chlorine-free refrigerant of the HFC group with zero ozone depletion potential
 - High-density refrigerant, therefore less refrigerant required

- Very efficient - gives an increased energy efficiency ratio

- Leak-tight refrigerant circuit
 - Brazed refrigerant connections for increased leaktightness
 - Reduction of leaks due to reduced vibration levels and elimination of capillary tubes (TXVs)
 - Verification of pressure transducers and temperature sensors without transferring refrigerant charge

Superior reliability

- State-of-the-art concept
 - Cooperation with specialist laboratories and use of limit simulation tools (finite element calculations) for the design of the critical components, e.g. motor supports, suction/discharge piping etc.
- Exceptional endurance tests
 - Corrosion resistance tests in salt mist in the laboratory
 - Accelerated ageing test on components that are submitted to continuous operation: compressor piping, fan supports
 - Transport simulation test in the laboratory on a vibrating table.



Integrated hydronic module



Partial view of the refrigeration circuit

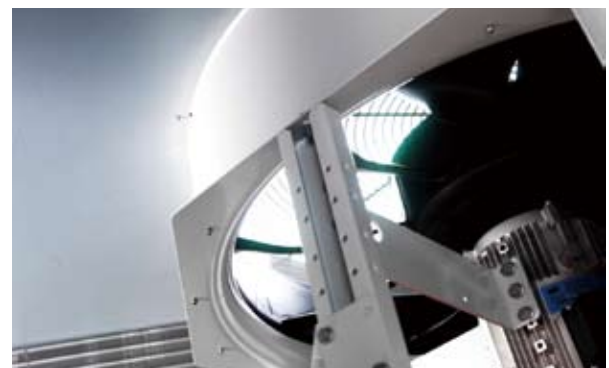

Flying Bird IV fan

Pro-Dialog Plus Control

Pro-Dialog Plus combines intelligence with operating simplicity. The control constantly monitors all machine parameters and precisely manages the operation of compressors, expansion devices, fans and of the evaporator water pump for optimum energy efficiency.

User-friendly interface

- The new backlighted LCD interface includes a manual control potentiometer to ensure legibility under any lighting conditions. The information is in clear text and can be displayed in English.
- Unit uses intuitive tree-structure menus, similar to the Internet navigators. They are user-friendly and permit quick access to the principal operating parameters: number of compressors operating, suction/discharge pressure, compressor operating hours, set point, air temperature, entering/leaving water temperature.

Pro-Dialog Plus interface

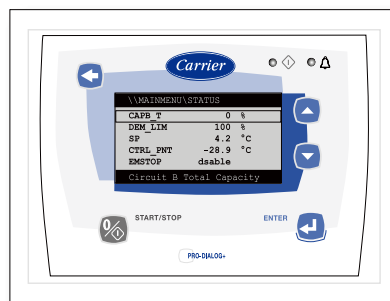

Advanced control function

- Unit provides different control mode including LOCAL/REMOTE/CCN.
- Remote control function including: Unit ON/OFF, dual set point control, demand limit control, user safety interlock, water pump control, operation indication, circuit alarm and alert etc.
- Enable automatic reset of leaving water temperature according to return water temperature or outside air temperature to ensure optimum energy efficiency.
- Control algorithm prevents excessive compressor cycling and permits reduction of the water quantity in the hydronic circuit (Carrier patent).
- Automatic compressor unloading in case of abnormally high condensing pressure. If an abnormal incident occurs (e.g. fouled condenser coil, fan failure), Aquasnap continues to operate, but at reduced capacity.

Powerful Diagnostics

- Unit can perform a quick test (manually or automatically) of all unit components and control points to verify the correct operation of unit
- Real-time monitor all the controls and operation parameter, alarm when necessary.
- Control system includes RS485 serial communication port for remote diagnosis or special diagnosis tools.

Sufficient safety measures

- Password protection in case of mishandling.
- Unit is protected against: compressor reverse, low chilled water temperature, high/low refrigerant pressure, excessive current, motor overload.

Group control

- Master/slave control of two chillers operating in parallel with operating time equalization and automatic changeover in case of a unit fault.
- Communication with other Building Management System (BMS) by selecting BacNet/J-Bus/LonTalk gateway.

Performance data

30RB		039S	060S	080S	100S	120S	160S
Nominal cooling capacity*	kW	39.7	59.8	80.5	100.9	118.0	157.9
Compressor power input	kW	13.0	20.4	27.1	34.4	41.7	54.8
EER	kW/kW	2.88	2.84	2.80	2.80	2.73	2.72
Operating weight							
Standard unit with hydronic module							
Fixed speed single pump	kg	488	545	562	877	912	1114
Fixed speed dual pump	kg	514	571	588	922	960	1151
Unit without hydronic module	kg	458	515	533	845	876	1075
Refrigerant							
HFC-410A							
Circuit A	kg	8.5	15.0	15.5	20.0	25.0	16.0
Circuit B	kg	-	-	-	-	-	16.0
Compressor							
Hermetic scroll compressors, 48.3r/s							
Circuit A		2	2	2	3	3	2
Circuit B		-	-	-	-	-	2
Number of capacity stages		2	2	2	3	3	4
Minimum capacity	%	50	50	50	33	33	25
Control							
Pro-Dialog Plus							
Condenser							
Grooved copper tubes and aluminium fins							
Fans							
Axial Flying Bird IV with rotating shroud							
Quantity		1	1	1	2	2	2
Total air flow	l/s	3800	3800	5300	7600	7600	10600
Speed	rpm	720	720	960	720	720	960
Evaporator							
Braze plate heat exchanger							
Water volume	l	2.6	4.0	5.6	9.9	11.3	14.7
Nominal water flow rate	l/s	1.9	2.9	3.8	4.8	5.6	7.5
Unit internal water pressure drop	kPa	41	60	65	55	63	78
Max. water-side operating pressure without hydronic module	kPa	1000	1000	1000	1000	1000	1000
Hydronic module							
Pump, Victaulic screen filter, safety valve, expansion tank, purge valves etc.							
Water pump		Horizontal single-stage centrifugal pump					
Water head external to chiller							
Single pump at nominal water flow rate	kPa	227	194	196	223	201	181
Dual pump at nominal water flow rate	kPa	223	190	191	217	194	168
Expansion tank	l	12	12	12	35	35	35
Max. water-side operating pressure with hydronic module	kPa	400	400	400	400	400	400
Water connection							
Victaulic							
Diameter		DN50	DN50	DN50	DN65	DN65	DN65
Electrical data							
Main power supply							
400V-3Ph-50Hz							
Control power supply							
Via internal transformer							
Nominal unit operating current draw	A	28	41	58	70	86	116
Maximum operating current draw	A	35	51	68	84	99	136
Maximum start-up current	A	115	146	212	199	243	280
Total fan power input	kW	0.8	0.7	1.6	1.5	1.5	3.2
Pump power input (single pump)	kW	1.3	1.3	1.8	2.1	2.3	4.7
Pump power input (dual pump)	kW	1.3	1.3	1.8	2.1	2.3	4.7

* Nominal cooling mode - evaporator entering/leaving water temperature 12/7°C, outside air temperature 35°C;
Evaporator fouling factor - 0.018m²K/kW.

Performance data

30RQ		039S	060S	078S	100S	120S	160S	
Nominal cooling capacity*		kW	38.3	58.6	74.3	99.0	150.3	
Compressor power input, cooling mode		kW	12.3	19.2	26.6	33.3	54.1	
EER		kW/kW	2.92	2.80	2.61	2.84	2.63	
Nominal heating capacity*		kW	41.4	61.3	77.7	101.4	158.7	
Compressor power input, heating mode		kW	12.6	18.0	24.6	30.5	48.7	
COP		kW/kW	3.08	3.09	2.94	3.15	3.04	
Operating weight								
Standard unit with hydronic module								
Fixed speed single pump		kg	535	582	590	935	1117	
Fixed speed dual pump		kg	561	608	616	980	1127	
Unit without hydronic module		kg	506	552	560	903	1078	
Refrigerant			HFC-410A					
Circuit A		kg	12.5	17.5	16.5	28.5	18.5	
Circuit B		kg	-	-	-	-	18.5	
Compressor			Hermetic scroll compressors, 48.3r/s					
Circuit A			2	2	2	3	2	
Circuit B			-	-	-	-	2	
Number of capacity stages			2	2	2	3	4	
Minimum capacity		%	50	50	50	33	25	
Control			Pro-Dialog Plus					
Air heat exchanger			Grooved copper tubes and aluminium fins					
Fans			Axial Flying Bird IV with rotating shroud					
Quantity			1	1	1	2	2	
Total air flow		l/s	3800	5300	5300	7600	10600	
Speed		rpm	720	960	960	720	960	
Water heat exchanger			Brazen plate heat exchanger					
Water volume		l	2.6	4.0	5.6	9.9	14.7	
Nominal water flow rate, cooling mode		l/s	1.8	2.8	3.5	4.7	7.2	
Nominal water flow rate, heating mode		l/s	2.0	2.9	3.7	4.8	7.6	
Nominal pressure drop, cooling mode		kPa	38	56	52	53	72	
Nominal pressure drop, heating mode		kPa	45	62	61	55	78	
Max. water-side operating pressure without hydronic module		kPa	1000	1000	1000	1000	1000	
Hydronic module			Pump, Victaulic screen filter, safety valve, expansion tank, purge valves etc.					
Water pump			Horizontal single-stage centrifugal pump					
Water head external to chiller								
Single pump at nominal water flow rate, cooling mode		kPa	230	209	211	223	188	
Dual pump at nominal water flow rate, cooling mode		kPa	226	205	207	217	176	
Single pump at nominal water flow rate, heating mode		kPa	219	205	197	219	176	
Dual pump at nominal water flow rate, heating mode		kPa	215	200	192	213	163	
Expansion tank		l	12	12	12	35	35	
Max. water-side operating pressure with hydronic module		kPa	400	400	400	400	400	
Water connection			Victaulic					
Diameter			DN50	DN50	DN50	DN65	DN65	
Electrical data			400V-3Ph-50Hz					
Main power supply			Via internal transformer					
Control power supply								
Nominal unit operating current draw		A	28	43	58	70	116	
Maximum operating current draw		A	35	53	68	84	136	
Maximum start-up current		A	115	148	212	199	280	
Total fan power input, cooling mode		kW	0.8	1.7	1.8	1.5	3.1	
Total fan power input, heating mode		kW	0.9	1.9	1.9	1.8	3.5	
Pump power input (single pump)		kW	1.3	1.4	1.7	2.1	4.6	
Pump power input (dual pump)		kW	1.3	1.4	1.7	2.1	4.6	

* Nominal cooling mode - evaporator entering/leaving water temperature 12/7°C, outside air temperature 35°C;

Nominal heating mode - water heat exchange entering/leaving water temperature 40/45°C, outside air temperature 7°C;

Water heat exchanger fouling factor - 0.018m²K/kW.

Cooling capacities, 30RB039S~160S

Model	LWT °C	Outside air temperature °C														
		25			30			35			40			45		
		CAP kW	COMP kW	FLOW l/s	CAP kW	COMP kW	FLOW l/s	CAP kW	COMP kW	FLOW l/s	CAP kW	COMP kW	FLOW l/s	CAP kW	COMP kW	FLOW l/s
039S	5	40.9	10.7	2.0	39.2	11.6	1.9	37.4	12.8	1.8	35.1	14.0	1.7	32.5	15.6	1.6
060S	5	62.8	16.4	3.0	59.9	18.1	2.9	55.9	20.1	2.7	51.2	22.2	2.4	46.3	24.7	2.2
080S	5	85.4	23.4	4.1	80.7	25.4	3.9	75.6	27.0	3.6	70.0	30.5	3.3	64.0	33.4	3.1
100S	5	107.1	27.8	5.1	101.6	30.4	4.9	95.3	33.3	4.5	88.2	36.6	4.2	80.4	40.0	3.8
120S	5	125.6	34.3	6.0	118.9	36.8	5.7	111.8	39.6	5.3	104.2	42.7	5.0	95.4	46.7	4.6
160S	5	167.3	45.2	8.0	158.2	49.0	7.6	148.3	53.1	7.1	137.6	57.8	6.6	125.9	63.1	6.0
039S	6	42.1	10.8	2.0	40.4	11.7	1.9	38.5	12.9	1.8	36.1	14.2	1.7	33.5	15.7	1.6
060S	6	65.0	16.5	3.1	62.1	18.3	3.0	57.8	20.3	2.8	53.1	22.4	2.5	48.0	24.8	2.3
080S	6	87.9	23.6	4.2	83.1	25.6	4.0	77.8	27.3	3.7	72.1	30.7	3.4	66.0	33.6	3.1
100S	6	110.2	28.2	5.3	104.6	30.8	5.0	98.0	33.7	4.7	90.8	37.0	4.3	82.8	40.4	4.0
120S	6	129.0	35.1	6.2	122.2	37.7	5.8	114.9	40.4	5.5	107.0	43.6	5.1	98.4	47.0	4.7
160S	6	172.6	45.9	8.2	163.2	49.7	7.8	153.0	53.9	7.3	141.9	58.6	6.8	129.9	63.9	6.2
039S	7	43.3	10.9	2.1	41.5	11.8	2.0	39.7	13.0	1.9	37.1	14.3	1.8	34.4	15.9	1.6
060S	7	67.2	16.6	3.2	64.2	18.4	3.1	59.8	20.4	2.9	55.0	22.5	2.6	49.7	25.0	2.4
080S	7	90.5	23.8	4.3	85.6	25.9	4.1	79.9	27.5	3.8	74.3	30.9	3.5	67.8	33.8	3.2
100S	7	113.5	28.6	5.4	107.7	31.2	5.1	100.9	34.4	4.8	93.4	37.5	4.5	85.2	40.9	4.1
120S	7	132.6	35.8	6.3	125.5	38.5	6.0	118.0	41.7	5.6	109.8	44.5	5.2	101.0	47.8	4.8
160S	7	178.1	46.7	8.5	168.4	50.5	8.0	157.9	54.8	7.5	146.5	59.5	7.0	134.1	64.7	6.4
039S	8	44.5	11.1	2.1	42.7	12.0	2.0	40.7	13.2	1.9	38.2	14.5	1.8	35.4	16.1	1.7
060S	8	69.4	16.8	3.3	66.4	18.6	3.2	61.9	20.6	3.0	56.9	22.7	2.7	51.5	25.1	2.5
080S	8	93.2	24.1	4.5	88.0	26.1	4.2	82.4	27.8	3.9	76.5	31.2	3.7	69.8	34.2	3.3
100S	8	116.8	29.0	5.6	110.7	31.7	5.3	103.7	34.7	5.0	96.1	38.0	4.6	87.6	41.4	4.2
120S	8	136.4	36.2	6.5	128.8	39.3	6.2	121.0	42.3	5.8	112.6	45.5	5.4	103.6	48.8	4.9
160S	8	183.6	47.5	8.8	173.5	51.3	8.3	162.8	55.6	7.8	151.1	60.4	7.2	138.4	65.5	6.6
039S	10	46.9	11.3	2.2	45.1	12.3	2.2	43.0	13.5	2.1	40.3	14.8	1.9	37.3	16.4	1.8
060S	10	74.0	17.1	3.5	70.7	18.8	3.4	66.1	20.9	3.2	60.9	23.0	2.9	55.3	25.5	2.6
080S	10	98.6	24.6	4.7	93.2	26.6	4.5	87.4	28.3	4.2	81.0	31.7	3.9	74.0	34.6	3.5
100S	10	123.5	29.9	5.9	117.0	32.6	5.6	109.5	35.6	5.2	101.4	38.9	4.8	92.4	42.4	4.4
120S	10	143.9	37.1	6.9	136.0	40.2	6.5	127.5	43.7	6.1	118.4	47.4	5.7	108.7	50.7	5.2
160S	10	195.1	48.5	9.3	184.4	52.8	8.8	172.9	57.4	8.3	160.6	62.2	7.7	147.2	67.4	7.0

Legend:

LWT leaving water temperature
 CAP cooling capacity
 COMP compressor power input
 FLOW water flow

Application data:

Standard units, refrigerant: HFC-410A
 Evaporator temperature rise: 5°C
 Fouling factor: 0.018 m²K/kW

Operating Range, 30RB039S~160S

Cooling mode		Minimum	Maximum
Evaporator			
Entering water temperature at start-up	°C	7.5	30
Leaving water temperature during operation	°C	5	20
Entering/leaving water temperature difference	K	3	10
Condenser			
Entering air temperature*	°C	-10	48

* Maximum outside temperature: For transport and storage of the 30RB units the minimum and maximum allowable temperatures are -20°C and +48°C. It is recommended that these temperatures are used for transport by container.

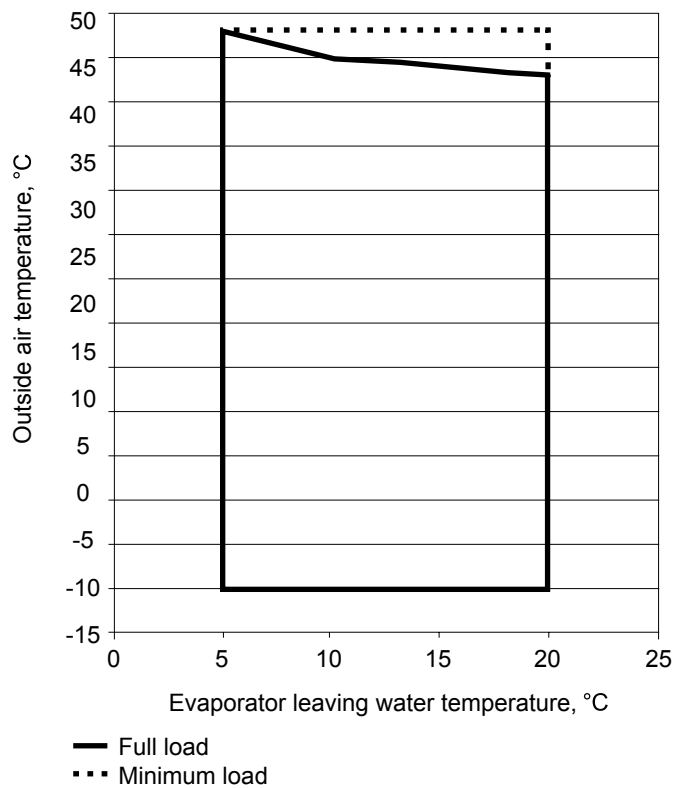

Operating Range, 30RQ039S~160S

Cooling mode		Minimum	Maximum
Water heat exchanger (Evaporator)			
Entering water temperature at start-up	°C	7.5	30
Leaving water temperature during operation	°C	5	20
Entering/leaving water temperature difference	K	3	10
Air heat exchanger (Condenser)			
Entering air temperature*	°C	-10	48

* Maximum outside temperature: For transport and storage of the 30RB units the minimum and maximum allowable temperatures are -20°C and +48°C. It is recommended that these temperatures are used for transport by container.

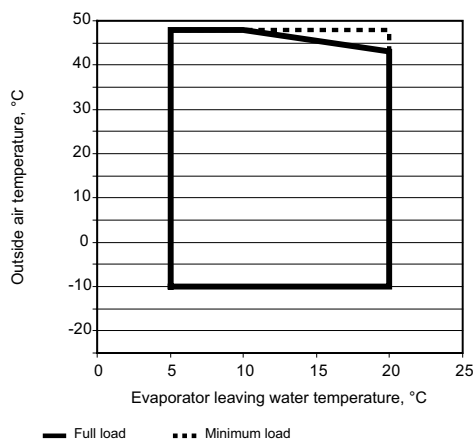

Heating mode		Minimum	Maximum
Water heat exchanger (Condenser)			
Entering water temperature at start-up	°C	8	30
Leaving water temperature during operation	°C	25	20
Entering/leaving water temperature difference	K	3	10
Air heat exchanger (Evaporator)			
Air temperature	°C	-15	48

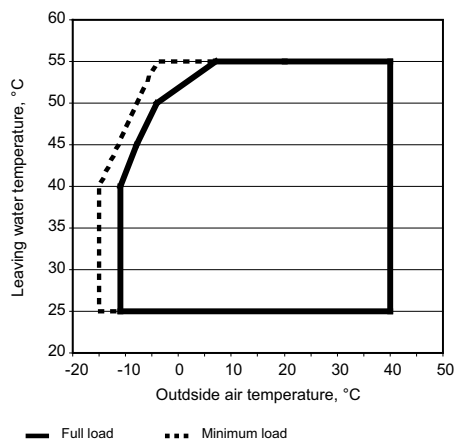

Options & accessories

Options	No.	Description	Advantages	Use
Blygold PoluAl	002B	Coils with factory-applied Blygold Polual treatment	Improved corrosion resistance, recommended for heavy marine and industrial environments	30RB039-160S
Gold Fins	003A	Fins made of pre-treated aluminium (polyurethane and epoxy)	Improved corrosion resistance, recommended for light marine environments	30RB039-160S
Super low noise	015LS	Acoustic compressor enclosure and low speed fans	Super low operating noise	30RB039-160S 30RQ039-160S
Soft starter	025	Electronic compressor starter	Reduced compressor start-up current	30RB039S-080S 30RQ039S-078S
Winter operation	028	Fan speed control by frequency inverter	Stable operation between -10°C and -20°C outdoor air temperature	30RB039S-080S
Fixed speed dual pump hydronic module	116C	Provide fixed speed dual pumps of 200KPa external pressure	Easy and fast installation, operating safety	30RB039-160S 30RQ039-160S
Unit without hydronic module	116D	Flexible for customer to purchase and install the water components by themselves	-	30RB039-160S 30RQ039-160S
J-Bus gateway	148B	Two-directional communication board with J-Bus protocol	Easy connection by communication bus to a building management system	30RB039-160S 30RQ039-160S
BacNet gateway	148C	Two-directional communication board with BacNet protocol	Easy connection by communication bus to a building management system	30RB039-160S 30RQ039-160S
LonTalk gateway	148D	Two-directional communication board with LonTalk protocol	Easy connection by communication bus to a building management system	30RB039-160S 30RQ039-160S



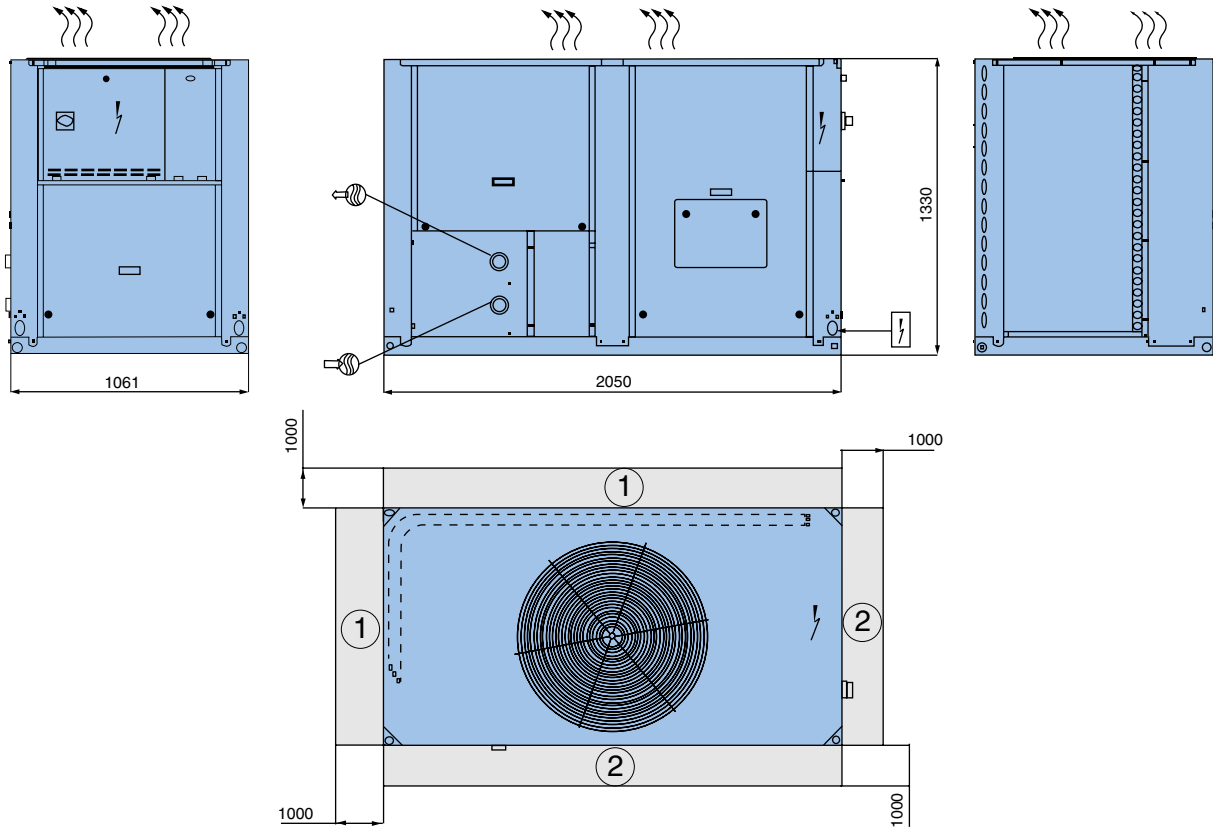

Dimensions/Clearances

30RB039S~080S/30RQ039S-078S



Legend:

All dimensions are given in mm

-  Control box
-  Water outlet
-  Water inlet
- ① Required clearances for air entry
- ② Recommended space for maintenance
-  Air outlet - do not obstruct
-  Power supply inlet



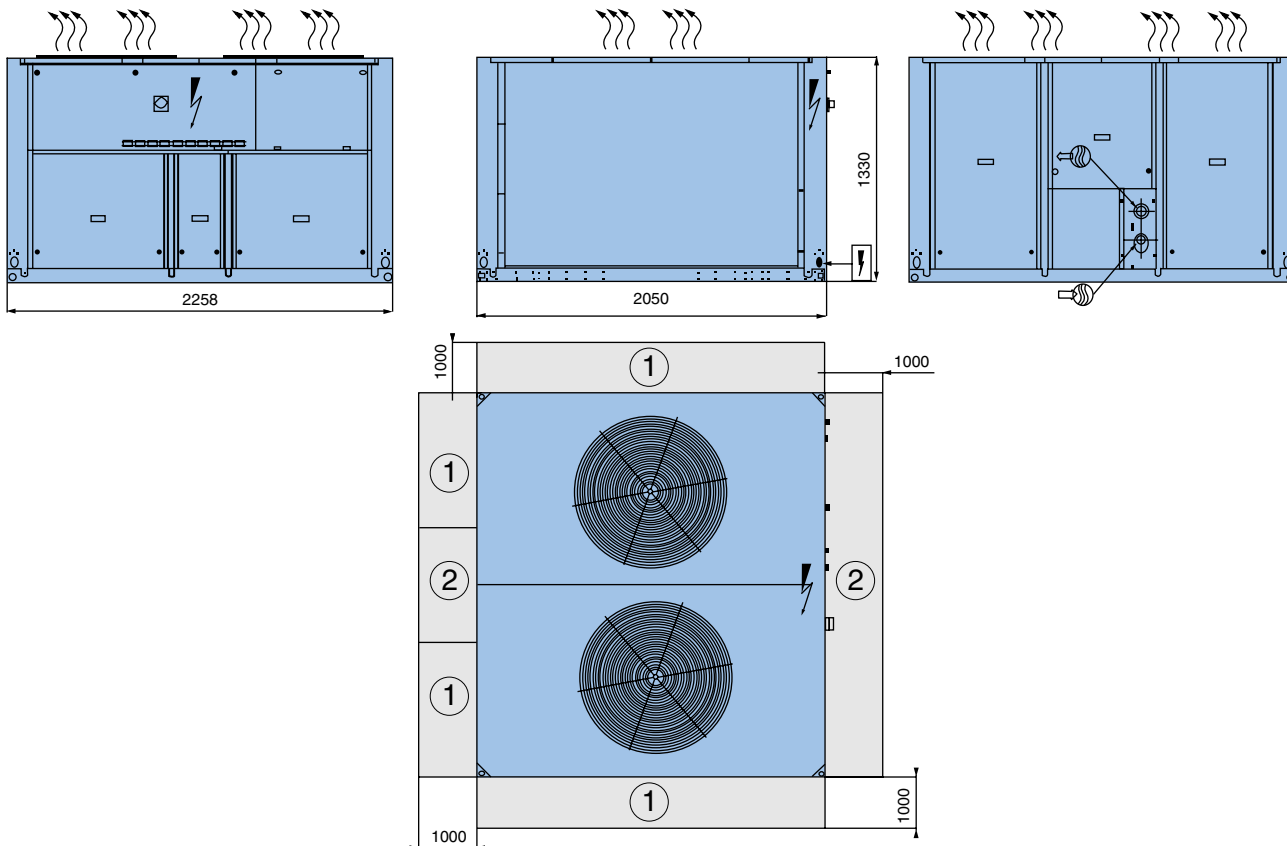

Dimensions/Clearances

30RB100S~160S/30RQ100S-160S



Legend:

All dimensions are given in mm

-  Control box
-  Water outlet
-  Water inlet
- ① Required clearances for air entry
- ② Recommended space for maintenance
-  Air outlet - do not obstruct
-  Power supply inlet

Multiple Chiller Installation

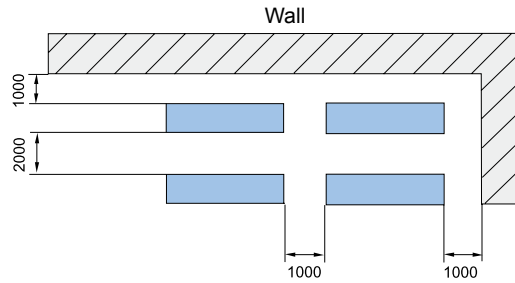
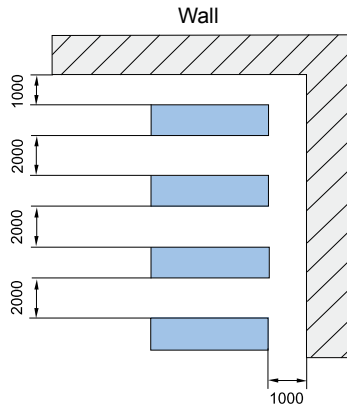

Note: If the height of wall exceeds 2m, please contact local Carrier Sales & Service Corporation.

Weight Distribution

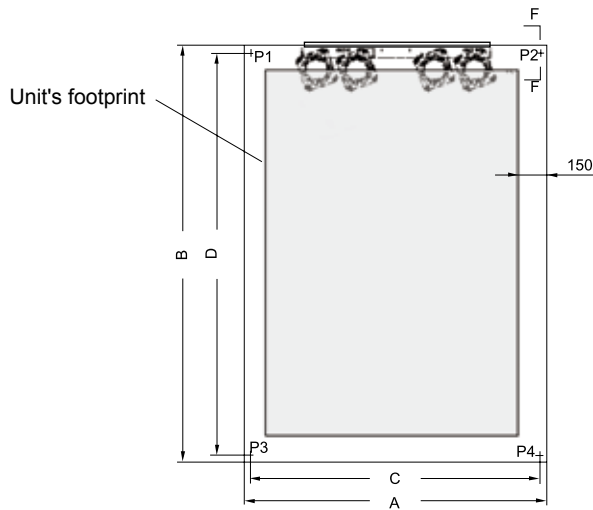

Square hole 100x100

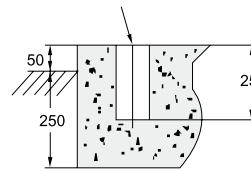

Section F - F

Note: 4 foot screws M16x220

Square hole 100x100

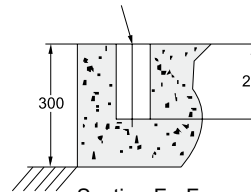

Section F - F

Note: 4 foot screws M16x220

Models	Dimensions (mm)				Weight distribution (kg)				Operating weight
	A	B	C	D	P1	P2	P3	P4	
30RB039S	1061	2050	1017	2002	159	147	87	94	488
30RB060S	1061	2050	1017	2002	176	154	100	115	545
30RB080S	1061	2050	1017	2002	181	159	104	118	562
30RB100S	2258	2050	2214	2002	239	303	187	148	877
30RB120S	2258	2050	2214	2002	246	310	199	157	912
30RB160S	2258	2050	2214	2002	312	357	237	207	1114
30RQ039S	1061	2050	1017	2002	174	161	96	103	535
30RQ060S	1061	2050	1017	2002	188	164	107	123	582
30RQ078S	1061	2050	1017	2002	190	167	109	124	590
30RQ100S	2258	2050	2214	2002	255	323	199	158	935
30RQ120S	2258	2050	2214	2002	268	338	217	171	995
30RQ160S	2258	2050	2214	2002	313	358	238	208	1117

Hydronic Connections

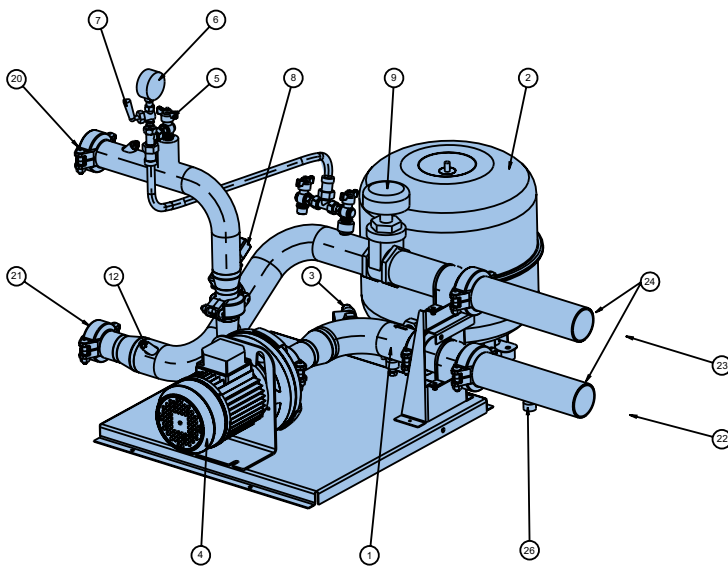
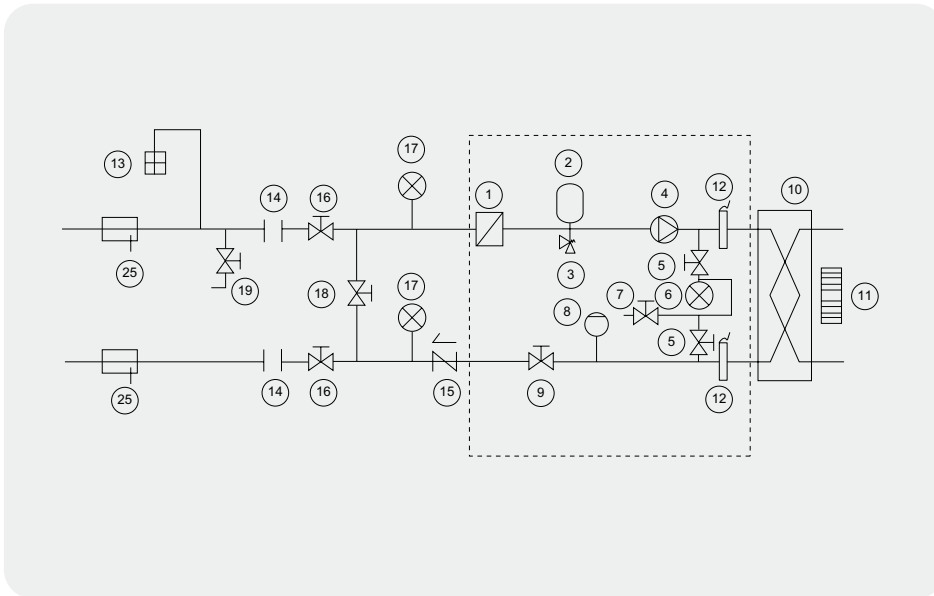

Legend:

Components of the unit and hydronic module

- 1 Victaulic screen filter
- 2 Expansion tank
- 3 Safety valve
- 4 Water pump
- 5 Purge valve and pressure tap
- 6 Pressure gauge
- 7 System air vent
- 8 Flow switch
- 9 Flow control valve
- 10 Brazed plate heat exchanger
- 11 Evaporator frost protection heater
- 12 Temperature sensor

Installation components

- 13 Air vent
- 14 Flexible connection
- 15 Check valve
- 16 Shut-off valve
- 17 Pressure gauge
- 18 Frost protection bypass valve
(must have when shut-off valves [16] are closed during winter)
- 19 Charge valve
- 20 Evaporator water inlet
- 21 Evaporator water outlet
- 22 Chiller water inlet
- 23 Chiller water outlet
- 24 Customer water connections (provided with chiller)
- 25 Temperature probe well
- 26 System drain valve

Unit Internal Water Pressure Drop

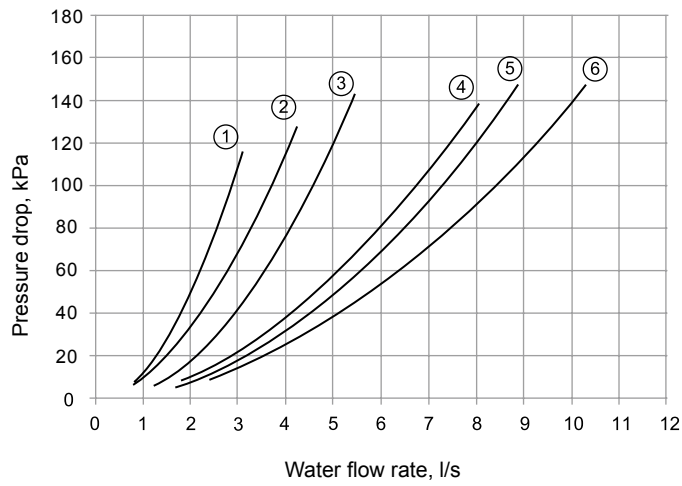

- ① 30RB039S/30RQ039S ② 30RB060S/30RQ060S ③ 30RB080S/30RQ078S
 ④ 30RB100S/30RQ100S ⑤ 30RB120S/30RQ120S ⑥ 30RB160S/30RQ160S

Available Static System Pressure

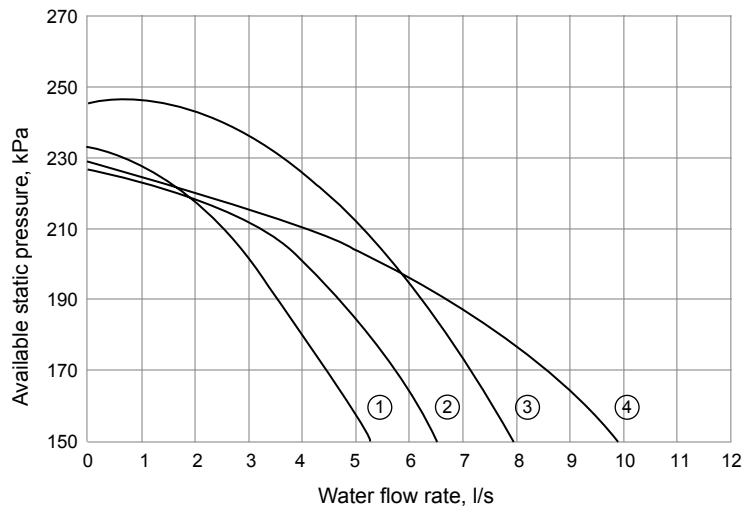

- ① 30RB039S~060S/30RQ039S~060S ② 30RB080S/30RQ078S
 ③ 30RB100S~120S/30RQ100S~120S ④ 30RB160S/30RQ160S

Minimum Water Loop Volume

For better control of leaving water temperature, the water loop minimum capacity is given by the formula:

$$\text{Capacity} = \text{CAP (kW)} \times \text{N Liters}$$

CAP: Unit's nominal cooling capacity

Application	N
Comfort air conditioning	
30RB 039S~160S/30RQ039S~160S	3.5
Process cooling	
30RB 039S~160S/30RQ039S~160S	Should be greater than 3.5 for better water temperature control

It is often necessary to add a buffer water tank to the circuit in order to achieve the required volume. The tank must itself be internally baffled in order to ensure proper mixing of the liquid (water or brine). Refer to the examples below.

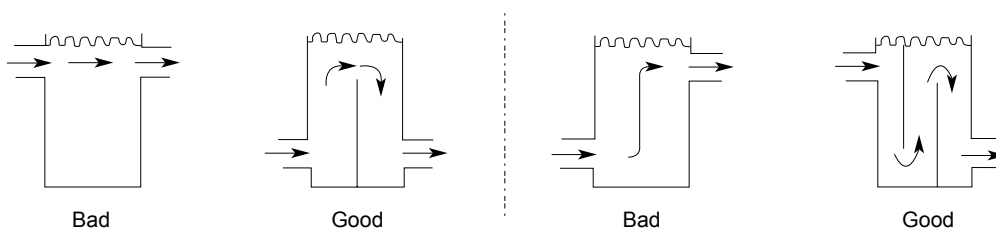

Maximum Water Loop Volume

The expansion tank of the unit with hydronic module limits the maximum water volume, refer to below sheet:

		30RB039S~080S/30RQ039S~078S			30RB100S~160S/30RQ100S~160S		
Water-side static pressure	kPa	100	200	300	100	200	300
Pure water	L	600	400	200	1680	1120	560
10%EG	L	450	300	150	1260	840	420
20%EG	L	330	220	110	930	620	310
30%EG	L	270	180	90	750	500	250
40%EG	L	225	150	75	630	420	210

EG: Ethylene glycol

Field Control Wiring

30RB039S~080S/30RQ039S~078S

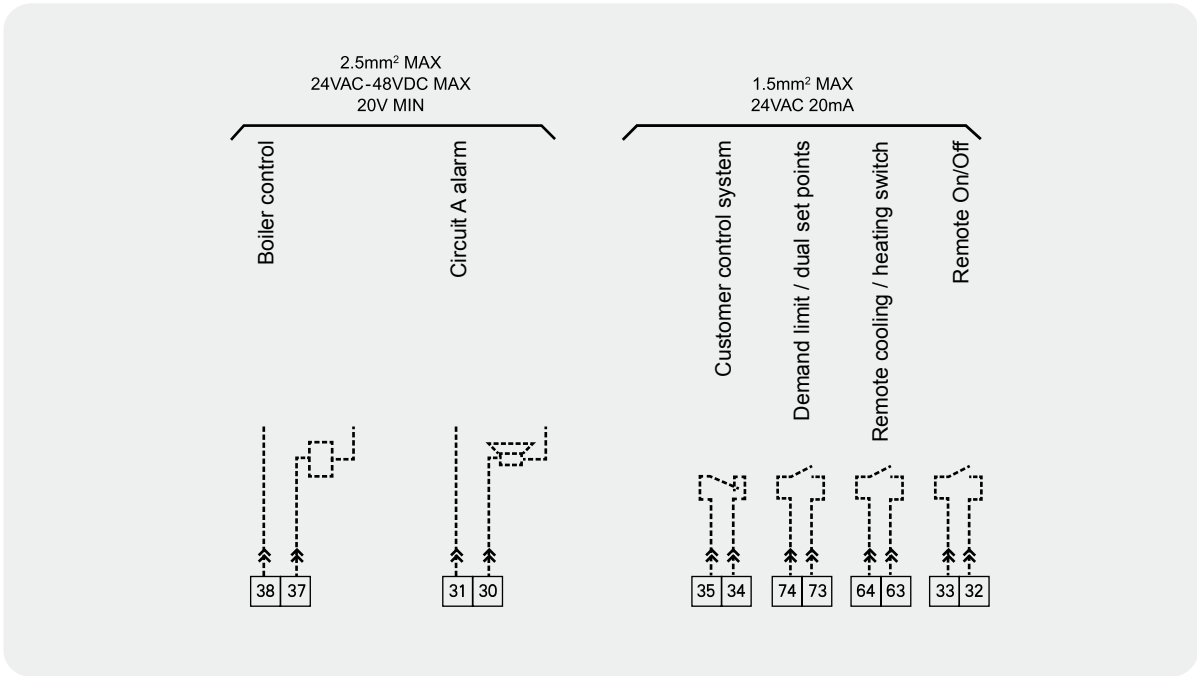

30RB100S~160S/30RQ100S~160S

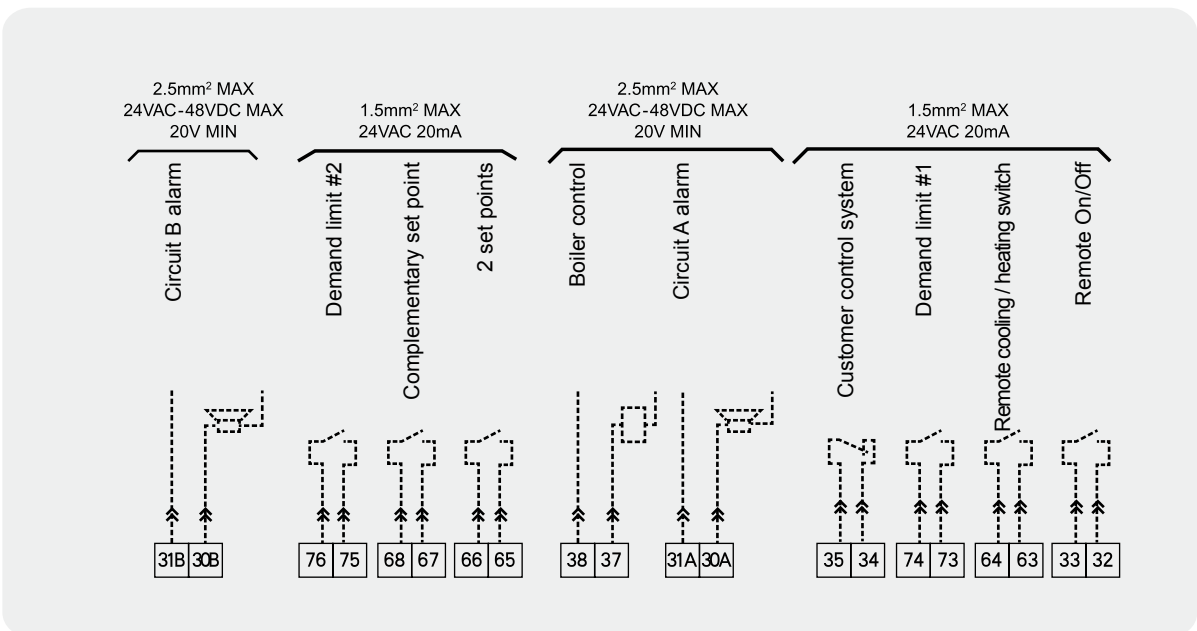

Carrier Corporation identified six specific areas of concentration that directly impact how we, as a world manufacturer, balance our customer' needs for comfort with the environment's needs for responsible consumption.

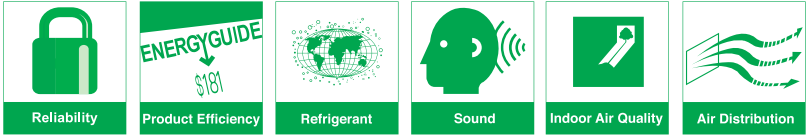

Welcome to Carrier Website
www.carrier.com.cn

