



AIR-COOLED LIQUID CHILLER REVERSIBLE AIR-TO-WATER HEAT PUMP

PRO-DIALOG PLUS

AQUASNAP™



* Unit with low noise option

30RB192-802/30RQ202-462

Refrigerant HFC-410A

Nominal cooling capacity 193-758 kW

Nominal heating capacity 217-510 kW

The Aquasnap Puron liquid chillers/air-to-water heat pumps are designed for commercial (air conditioning of villa, supermarket, office, hotel hospital etc.) or industrial (low-temperature process chillers etc.) applications.

Benefits:

- Environment sound refrigerant HFC-410A of zero ozone depletion potential.
- Standard unit with hydronic module (except for 30RB672/802) including all necessary hydronic components, easy and fast installation to save time, space and money.
- Low operating sound with no intrusive low-frequency noise, creates a better working/living environment.
- Electronic expansion valve (EXV) utilization, several compressors connected in parallel lead to more economical operating cost.
- Exceptional endurance tests ensure superior reliability to minimize chiller down-time.

Features

Environmental sound

- Ozone-friendly HFC-410A refrigerant
 - Chlorine-free refrigerant of the HFC group with zero ozone depletion potential
 - Very efficient - gives an increased energy efficiency ratio
- Leak-tight refrigerant circuit
 - Brazed refrigerant connections for increased leaktightness
 - Reduction of leaks as no capillary tubes and flare connections are used
 - Verification of pressure transducers and temperature sensors without transferring refrigerant charge

Easy and fast installation

- Integrated hydronic module(except for 30RB672/802)
 - Centrifugal high or low-pressure water pump (as required)

Features

- Single or dual pump (as required) with operating time balancing and automatic changeover to the back-up pump if a fault develops
- Water filter protects the water pump against circulating debris
- High-capacity membrane expansion tank ensures pressurization of the water circuit
- Thermal insulation and anti-freeze protection down to -20°C by using an electric resistance heater
- Simplified electrical connections
 - A single power supply point without neutral (except for 30RB672/802)
 - Main disconnect switch with high trip capacity
 - Transformer for safe 24 V control circuit supply included
- Fast commissioning
 - Systematic factory operation test before shipment
 - Quick-test function for step-by-step verification of the instruments, electrical components and motors

Quiet operation

- Compressors
 - Low-noise scroll compressors with low vibration level.
 - The compressor assembly is installed on an independent chassis and supported by anti-vibration mountings.
 - Dynamic suction and discharge piping support minimize vibration transmission (Carrier patent).
 - Acoustic compressor enclosure reduces radiated noise emission (option).
- Condenser section
 - Condenser coils in V-shape with an open angle allows quieter air flow across the coil.
 - Low-noise 4th generation Flying Bird fans (Carrier patent) enjoy quieter operation and never generate intrusive low-frequency noise.
 - Rigid fan mounting preventing start-up noise (Carrier patent).

Economical operation

- Increased energy efficiency at part load
 - The refrigerant circuit includes several compressors connected in parallel. At part load, around 99% of the operating time, only the compressors that are absolutely necessary operate. At these conditions the compressors operating are even more energy efficient, as they use the total condenser and evaporator capacity.
 - The electronic expansion device (EXV) allows operation at a lower condensing pressure (EER and COP optimization).
 - Dynamic superheat management for better utilization of the evaporator heat exchange surface.
- Reduced maintenance costs
 - Maintenance-free scroll compressors
 - Fast diagnosis of possible incidents and their history via the Pro-Dialog Plus control
 - HFC-410A refrigerant is easier to use than other refrigerant blends

Absolute reliability

- State-of-the-art concept
 - Cooperation with specialist laboratories and use of limit simulation tools (finite element calculations) for the design of the critical components, e.g. motor supports, suction/discharge piping etc.
- Exceptional endurance tests
 - Corrosion resistance tests in salt mist in the laboratory
 - Accelerated ageing test on components that are submitted to continuous operation: compressor piping, fan supports
 - Transport simulation test in the laboratory on a vibrating table. The test is based on a military standard and equivalent to 4000 km by truck.



Integrated hydronic module



Flying Bird IV axial flow low noise fan



Hermetic scroll compressor

Pro-Dialog Plus Control

Pro-Dialog Plus combines advanced control logic with simple operation. The control system monitors all operation parameters all the time and precisely manages the operation of compressors, electronic expansion devices, fans and water pumps for optimized energy efficiency.



User-friendly interface

- User interface with synoptic diagram for intuitive display of the principal operating parameters: number of compressors operating, suction/discharge pressure, compressor operating hours, set-point, air temperature, entering/leaving water temperature.
- Ten menus for direct access to all machine commands, including fault history, allowing fast and complete chiller diagnostics.

Advanced control function

- Unit provides different control mode including LOCAL/REMOTE/CCN.
- Remote control function including: Unit ON/OFF, dual set point control, 2-level demand limit control, user safety interlock, water pump operation control, operation indication, circuit alarm and alert etc.
- Automatic reset of leaving water temperature based on return water temperature or outside air temperature to ensure optimized energy efficiency.
- Control algorithm prevents excessive compressor cycling and permits reduction of the water quantity in the hydronic circuit (Carrier patent).
- Automatic compressor unloading in case of abnormally high condensing pressure. If an abnormal incident occurs (e.g. fouled condenser coil, fan failure), Aquasnap continues to operate, but at reduced capacity.

Powerful Diagnostics

- A quick test of all unit components and control points to verify the correct operation of every switch, circuit breaker, contactor etc. at the start of the chiller.
- Real-time monitor all the operation parameter, and alarm when necessary.
- Control system is facilitated with RS485 serial communication port for remote diagnosis or special diagnosis tools.

Sufficient safety measures

- Password protection in case of mishandling.
- Unit is protected against: Loss of refrigerant charge, reverse rotation, low chilled water temperature, current imbalance, compressor thermal overload, excessive air temperature, high pressure, electrical overload, loss of phase.

Group control

- Master/slave control of two chillers connected to automatically balance operating times, and also automatically conduct change-over in case of a unit fault.
- Communication with other Building Management System (BMS) by selecting BACnet/J-Bus/LonTalk gateway.

Technical Specifications

Performance data

30RB		192PT254	232PT254	262PT254	342PT254	402PT254	522PT254	672PT116D/254**	802PT116D/254**
Nominal cooling capacity*	kW	193	222	263	328	391	506	652	758
Compressor power input	kW	64.3	66.9	91.2	113.0	137.1	178.7	224.8	269.0
EER	kW/kW	2.7	3.0	2.7	2.7	2.7	2.6	2.7	2.6
Operating weight									
Unit with single pump hydronic module	kg	2320	2330	2510	3320	3550	4480	-	-
Unit without hydronic module	kg	2130	2140	2320	3120	3310	4190	5640	6510
Refrigerant		HFC-410A							
Circuit A	kg	24.0	24.0	24.0	37.0	38.5	47.5	38.5	48.0
Circuit B	kg	24.0	24.0	24.0	26.0	38.5	47.5	38.5	48.0
Circuit C	kg	-	-	-	-	-	-	48.0	48.0
Compressor		Hermetic scroll compressors							
Circuit A		1	2	2	3	3	4	3	4
Circuit B		2	2	2	2	3	4	3	4
Circuit C		-	-	-	-	-	-	4	4
Number of capacity stages		3	4	4	5	6	8	10	12
Minimum capacity	%	33	25	25	20	17	13	10	8
Control		Pro-Dialog Plus							
Condenser		Grooved copper tubes and aluminium fins							
Fans		Axial Flying Bird IV with rotating shroud							
Quantity		4	4	4	5	6	8	10	12
Total air flow	l/s	18056	18056	18056	22567	27081	36107	45134	54161
Speed	rpm	960	960	960	960	960	960	960	960
Evaporator		Direct expansion shell-and-tube							
Water volume	l	121	110	110	125	125	113	284	284
Nominal water flow rate	l/s	9.2	10.6	12.6	15.6	18.7	24.1	31.0	36.1
Unit internal water pressure drop	kPa	26	37	47	46	64	96	43	57
Max. water-side operating pressure without hydronic module	kPa	1000	1000	1000	1000	1000	1000	1000	1000
Hydronic module		Pump, victaulic screen filter, safety valve, expansion tank, purge valves etc.							
Water pump		Centrifugal pump							
Water head external to chiller									
High pressure pump at nominal water flow rate	kPa	177	205	181	182	201	210	-	-
Expansion tank	l	50	50	50	80	80	80	-	-
Max. water-side operating pressure with hydronic module	kPa	400	400	400	400	400	400	-	-
Water connection		Victaulic							
Diameter (with hydronic module)		DN100	DN100	DN100	DN100	DN100	DN125	-	-
Diameter (without hydronic module)		DN100	DN100	DN100	DN100	DN100	DN150	DN150	DN150
Electrical data		400V-3Ph-50Hz							
Main power supply		Via internal transformer							
Control power supply									
Nominal unit operating current draw, circuit A+B	A	137	143	175	219	265	354	251	334
Nominal unit operating current draw, circuit C	A	-	-	-	-	-	-	167	167
Maximum operating current draw, circuit A+B	A	176	183	227	284	343	458	329	438
Maximum operating current draw, circuit C	A	-	-	-	-	-	-	219	219
Maximum start-up current, circuit A+B	A	383	356	434	492	551	667	535	645
Maximum start-up current, circuit C	A	-	-	-	-	-	-	426	426
Total fan power input	kW	6.4	6.4	6.4	7.9	9.5	12.7	15.9	19.1
Pump power input (high pressure single pump)	kW	4.7	4.7	4.7	6.4	8.4	12.1	-	-

* Nominal cooling mode - evaporator entering/leaving water temperature 12/7°C, outside air temperature 35°C, Evaporator fouling factor-0.018m²K/kW.

** Integrated hydronic module is not suitable for 30RB672/802.

Technical Specifications

Performance data

30RQ		202	232	302	372	432	462
Nominal cooling capacity*	kW	195	221	275	331	389	430
Compressor power input	kW	65.8	70.8	98.1	115.8	139.1	153.6
EER	kW/kW	2.7	2.9	2.6	2.6	2.6	2.6
Nominal heating capacity*	kW	217	234	307	364	450	510
Compressor power input	kW	68.8	71.8	102.1	116.8	147.1	167.6
COP	kW/kW	2.9	3.0	2.8	2.9	2.8	2.8
Operating weight							
Unit with high-pressure single pump hydronic module	kg	2425	2431	3245	3558	4268	4454
Unit without hydronic module	kg	2235	2241	3045	3284	4028	4210
Refrigerant		HFC-410A					
Circuit A	kg	26.0	27.0	41.0	54.0	54.0	54.0
Circuit B	kg	26.0	27.0	27.0	32.0	47.0	53.0
Compressor		Hermetic scroll compressors					
Circuit A		1	2	3	4	4	4
Circuit B		2	2	2	2	3	4
Number of capacity stages		3	4	5	6	7	8
Minimum capacity	%	33	25	20	17	14	13
Control		Pro-Dialog Plus					
Air heat exchanger		Grooved copper tubes and aluminium fins					
Fans		Axial Flying Bird IV with rotating shroud					
Quantity		4	4	5	6	7	8
Total air flow	l/s	18056	18056	22569	27083	31597	36111
Speed	rpm	960	960	960	960	960	960
Water heat exchanger		Direct expansion shell-and-tube					
Water volume	l	110	110	110	113	113	113
Nominal water flow rate, cooling mode	l/s	9.4	10.3	13.6	16.4	19.3	21.7
Nominal water flow rate, heating mode	l/s	10.5	10.9	15.2	18.0	22.3	25.7
Unit internal water pressure drop, cooling mode	kPa	23	26	39	31	41	51
Unit internal water pressure drop, heating mode	kPa	27	28	45	37	54	71
Max. water-side operating pressure without hydronic module	kPa	1000	1000	1000	1000	1000	1000
Hydronic module		Pump, victaulic screen filter, safety valve, expansion tank, purge valves etc.					
Water pump		Centrifugal pump					
Water head external to chiller							
High pressure pump at nominal water flow rate, cooling mode	kPa	173	211	183	225	198	245
High pressure pump at nominal water flow rate, heating mode	kPa	162	203	164	205	152	178
Expansion tank	l	50	50	80	80	80	80
Max. water-side operating pressure with hydronic module	kPa	400	400	400	400	400	400
Water connection		Victaulic					
Diameter (with hydronic module)		DN100	DN100	DN100	DN125	DN125	DN125
Diameter (without hydronic module)		DN100	DN100	DN100	DN150	DN150	DN150
Electrical data		400V-3Ph-50Hz					
Main power supply		Via internal transformer					
Control power supply							
Nominal unit operating current draw	A	137	143	195	233	282	322
Maximum operating current draw	A	176	183	251	299	364	414
Maximum start-up current	A	383	356	459	507	573	623
Total fan power input	kW	6.2	6.2	7.9	9.2	10.9	12.4
Pump power input (high pressure single pump)	kW	4.7	4.7	6.4	8.5	8.5	12.2

* Nominal cooling mode - evaporator entering/leaving water temperature 12/7°C, outside air temperature 35°C;
 Nominal heating mode - water heat exchange entering/leaving water temperature 40/45°C, outside air temperature 7°C;
 Evaporator fouling factor - 0.018m²/kW.

Cooling capacities

Models	LWT °C	OAT°C														
		25			30			35			40			45		
		CAP kW	COMP kW	FLOW l/s	CAP kW	COMP kW	FLOW l/s	CAP kW	COMP kW	FLOW l/s	CAP kW	COMP kW	FLOW l/s	CAP kW	COMP kW	FLOW l/s
192PT254	5	201	51.9	9.6	191	57.1	9.1	180	62.9	8.6	168	69.1	8.0	155	76.1	7.4
232PT254	5	237	53.8	11.3	225	59.5	10.7	212	66.0	10.1	196	73.1	9.4	180	81.2	8.6
262PT254	5	278	73.8	13.3	264	81.1	12.6	248	88.9	11.8	231	97.4	11.0	214	106.9	10.2
342PT254	5	345	91.3	16.4	327	100.5	15.6	308	110.2	14.7	286	120.7	13.6	264	132.5	12.6
402PT254	5	412	110.8	19.6	391	122.0	18.6	368	133.9	17.5	342	146.9	16.3	316	161.4	15.1
522PT254	5	532	144.5	25.3	506	158.9	24.1	477	174.2	22.7	445	190.8	21.2	412	209.3	19.6
672PT116D/254	5	687	181.9	32.7	653	200.1	31.1	614	219.5	29.3	573	240.7	27.3	531	264.2	25.3
802PT116D/254	5	799	217.7	38.0	758	239.0	36.1	714	261.7	34.0	665	286.2	31.7	615	313.7	29.3
192PT254	6	209	52.5	9.9	198	57.8	9.4	186	63.6	8.9	174	69.9	8.3	161	76.8	7.7
232PT254	6	242	54.3	11.5	230	60.0	11.0	217	66.4	10.3	202	73.5	9.6	185	81.5	8.8
262PT254	6	287	74.8	13.7	272	82.2	13.0	256	90.0	12.2	238	98.6	11.4	220	108.1	10.5
342PT254	6	356	92.7	16.9	338	101.8	16.1	318	111.6	15.1	296	122.2	14.1	273	134.0	13.0
402PT254	6	425	112.2	20.2	403	123.5	19.2	379	135.5	18.1	353	148.6	16.8	327	327.0	15.6
522PT254	6	549	146.6	26.2	522	161.1	24.9	493	176.6	23.5	460	193.4	21.9	427	212.1	20.3
672PT116D/254	6	707	184.2	33.7	672	202.6	32.0	633	222.1	30.2	591	243.4	28.1	547	267.1	26.1
802PT116D/254	6	823	221.0	39.2	782	242.5	37.2	735	265.3	35.0	686	290.0	32.7	635	317.6	30.2
192PT254	7	216	53.2	10.3	205	58.5	9.8	193	64.3	9.2	180	70.6	8.6	167	77.6	7.9
232PT254	7	247	54.7	11.8	235	60.5	11.2	222	66.9	10.6	207	73.8	9.9	190	81.9	9.1
262PT254	7	295	75.9	14.1	280	83.4	13.4	263	91.2	12.6	245	99.8	11.7	227	109.4	10.8
342PT254	7	367	94.2	17.5	348	103.4	16.6	328	113.0	15.6	305	123.7	14.5	282	135.6	13.4
402PT254	7	438	113.7	20.9	416	125.0	19.8	391	137.1	18.7	364	150.2	17.4	337	164.9	16.1
522PT254	7	564	148.5	26.9	537	163.1	25.6	506	178.7	24.1	473	195.6	22.6	439	214.5	20.9
672PT116D/254	7	728	186.8	34.7	692	205.2	33.0	652	224.8	31.0	608	246.2	29.0	564	270.1	26.9
802PT116D/254	7	850	224.4	40.5	806	246.2	38.4	758	269.0	36.1	707	293.9	33.7	654	321.7	31.1
192PT254	8	224	54.0	10.7	213	59.3	10.2	200	65.0	9.6	187	71.4	8.9	172	78.4	8.2
232PT254	8	252	55.2	12.0	240	61.0	11.4	227	67.4	10.8	212	74.2	10.1	195	82.2	9.3
262PT254	8	304	77.0	14.5	288	84.6	13.8	271	92.4	12.9	253	101.0	12.1	234	110.7	11.2
342PT254	8	379	95.8	18.1	359	105.0	17.1	338	114.7	16.1	314	125.2	15.0	291	137.2	13.9
402PT254	8	452	115.4	21.5	429	126.7	20.4	403	138.7	19.2	375	151.9	17.9	348	166.7	16.6
522PT254	8	581	150.7	27.7	552	165.3	26.3	520	180.8	24.8	486	197.9	23.2	451	216.9	21.5
672PT116D/254	8	749	189.4	35.7	712	208.0	33.9	671	227.5	32.0	626	249.0	29.9	580	273.1	27.7
802PT116D/254	8	878	227.8	41.8	832	249.9	39.7	780	272.8	37.2	728	297.9	34.7	674	325.9	32.1
192PT254	10	239	55.5	11.4	227	60.9	10.9	214	66.7	10.2	200	73.0	9.5	185	80.0	8.8
232PT254	10	266	56.4	12.7	253	62.2	12.1	239	68.7	11.4	222	75.5	10.6	205	83.1	9.8
262PT254	10	321	79.4	15.3	305	87.0	14.6	286	94.9	13.7	267	103.6	12.8	248	113.4	11.8
342PT254	10	403	99.2	19.2	382	108.6	18.3	359	118.3	17.1	334	128.8	15.9	309	140.7	14.8
402PT254	10	479	119.1	22.9	455	130.6	21.7	428	142.5	20.4	398	155.4	19.0	369	170.4	17.6
522PT254	10	617	155.4	29.5	587	170.4	28.0	552	185.9	26.3	513	202.7	24.5	476	221.9	22.7
672PT116D/254	10	791	194.9	37.8	752	213.8	35.9	708	233.5	33.8	662	255.1	31.6	614	279.2	29.3
802PT116D/254	10	935	234.9	44.7	887	257.5	42.4	832	280.7	39.7	773	306.2	36.9	714	334.7	34.1

Legend:

LWT leaving water temperature
 CAP cooling capacity
 COMP compressor power input
 FLOW water flow

Operating Range, 30RB192-802

Evaporator water temperature

	°C	Minimum	Maximum
Entering water temperature at shut-down	-	-	48
Entering water temperature at start-up	6.8	6.8	40
Entering water temperature during operation	6.8	6.8	25
Leaving water temperature during operation	3.3	3.3	15

Condenser air temperature

	°C	Minimum	Maximum
Standard unit	0	0	48
With winter operation option (No. 28)	-20	-20	48
With winter operation B option (No. 28B)	-10	-10	48

Operating range

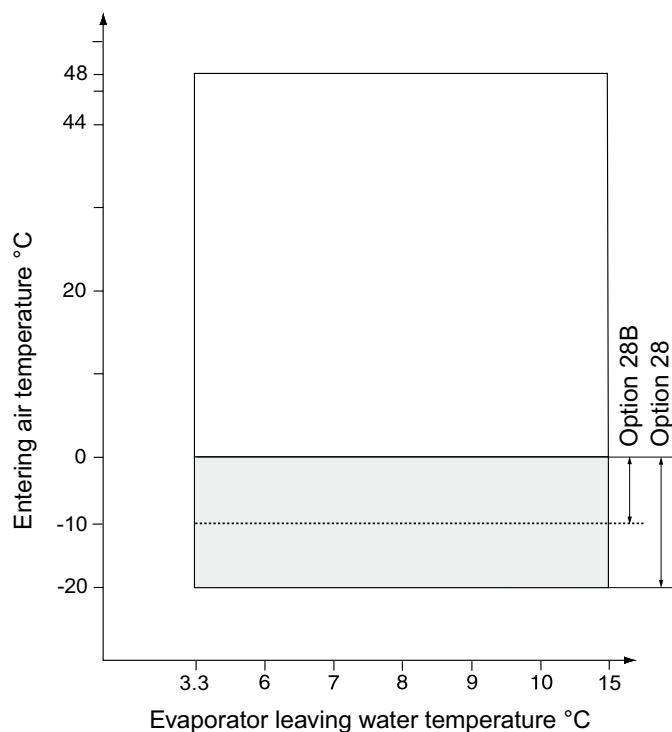

Note: Evaporator and condenser $\Delta t = 5$ K

- Standard unit operating range.
- Operating range, unit equipped with options 28 or 28B "Winter operation". In addition the unit must either be equipped with anti-freeze protection option for the evaporator and the hydronic module (if used), or the water loop must be protected against frost by the installer, using an anti-freeze solution.

Operating Range, 30RQ202-462

Cooling mode

Water heat exchanger (evaporator)	°C	Minimum	Maximum
Entering water temperature at start-up		6.8	30
Leaving water temperature during operation		5	15
Entering water temperature at shut-down		-	60
Air heat exchanger (condenser)	°C		
Air entering temperature		0	46

Heating mode

Water heat exchanger (condenser)	°C	Minimum	Maximum
Entering water temperature at start-up		8	45
Leaving water temperature during operation		20	50
Entering water temperature at shut-down		3	60
Air heat exchanger (evaporator)	°C		
Air entering temperature		-10	35

Operating range – cooling mode

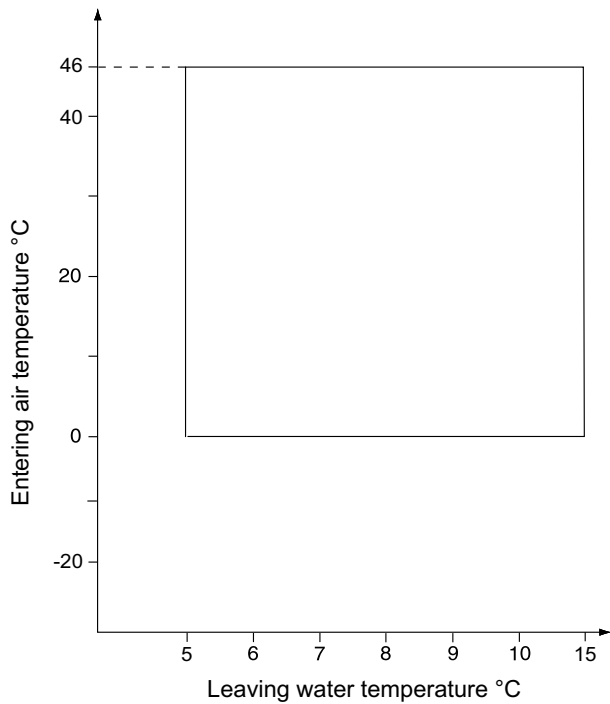

Operating range – heating mode

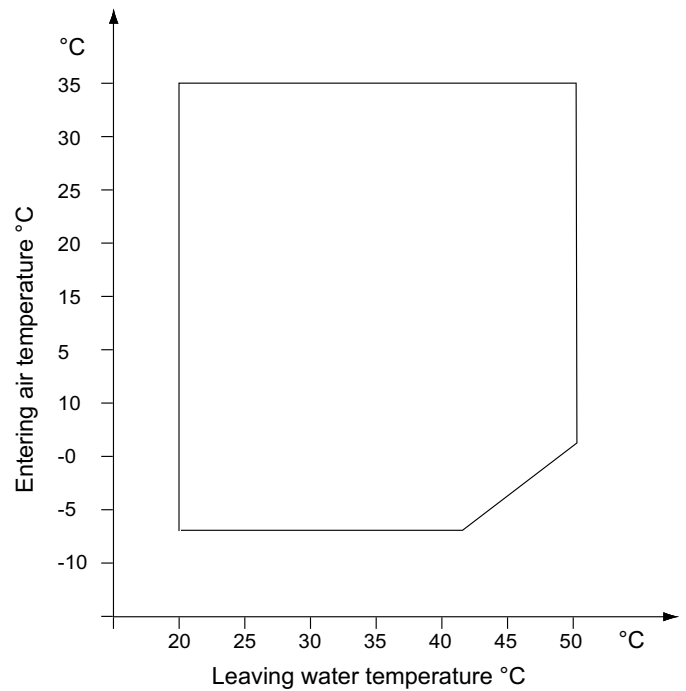

Note: Water heat exchanger and air heat exchanger $\Delta t = 5 \text{ K}$

Operating range, standard unit

Options & accessories

Options	No.	Description	Advantages	Use
Blygold PoluAL	002B	Coil with factory-applied Blygold PoluAL treatment	Improved corrosion resistance, recommended for heavy marine and industrial environments	30RB192~802
Gold Fin	003A	Fin made of pre-treated aluminium (polyurethane and epoxy)	Improved corrosion resistance, recommended for light marine environments	30RB192~802
Low brine	006	Leaving water temperature down to -10 °C	For low temperature applications such as ice storage, cold stores or process cooling etc.	30RB192~402
Low noise	015	Compressor sound enclosure	Low operating noise	30RB192~802 30RQ202~462
Super low noise	015LS	Compressor sound enclosure and low-speed fan	Super low operating noise	30RB192~802
MCHX bare coil	018	Micro-channel heat exchanger	30% reduction of refrigerant charge amount and convenient to clean by a high pressure washer	30RB192~802
Protection grilles	023	Metallic grilles on the four unit faces	Better chiller protection and aesthetics	30RB192~802 30RQ202~462
Winter operation	028	Fan speed control by frequency inverter	Stable operation between 0 °C and -20 °C outdoor air temperature	30RB192~802
Winter operation B	028B	Two-speed fan motor for each circuit	Stable operation between 0°C and -10 °C outdoor air temperature	30RB192~802
Partial heat recovery	049	Partial heat recovery by desuperheating the compressor discharge gas	Free high-temperature hot-water production simultaneously with chilled water production	30RB192~802 30RQ202~462
Full heat recovery	050	Heat recovery water cooled condenser	Free hot water production simultaneously with chilled water production	30RB262~522
Twinning	058	Unit equipped with an additional field-installed leaving water temperature sensor, allowing master/slave operation of two heat pumps connected in parallel	Optimized operation of two units connected in parallel with operating time equalization	30RB192~802 30RQ202~462
Suction valve	092	Shut-off valves on the compressor suction piping (discharge valve as standard)	Simplified maintenance	30RB192~802 30RQ202~462
High pressure dual pump hydronic module	116C	Provide integrated hydronic module with high pressure dual pump	Easy and fast installation, operating safety	30RB192~522 30RQ202~462

Options & accessories

Options	No.	Description	Advantages	Use
Unit without hydronic module	116D	Flexible for customer to purchase and install the water components by themselves	-	30RB192~802 30RQ202~462
Low pressure single pump hydronic module	116F	Provide integrated hydronic module with low pressure single pump	Easy and fast installation	30RB192~522 30RQ202~462
Low pressure dual pump hydronic module	116G	Provide integrated hydronic module with low pressure dual pump	Easy and fast installation, operating safety	30RB192~522 30RQ202~462
Super high pressure single pump hydronic module	116H	Provide integrated hydronic module with super high pressure single pump	Easy and fast installation	30RB192~522 30RQ202~462
Super high pressure dual pump hydronic module	116I	Provide integrated hydronic module with super high pressure dual pump	Easy and fast installation, operating safety	30RB192~522 30RQ202~462
J-Bus gateway	148B	Two-directional communication board with J-Bus protocol	Easy connection by communication bus to building management system	30RB192~802 30RQ202~462
BacNet gateway	148C	Two-directional communication board with BacNet protocol	Easy connection by communication bus to building management system	30RB192~802 30RQ202~462
LonTalk gateway	148D	Two-directional communication board with LonTalk protocol	Easy connection by communication bus to building management system	30RB192~802 30RQ202~462
Energy Management Module (EMM)	156	See control manual	-	30RB192~802 30RQ202~462
Cu/Al condenser coils	254	Coils made of copper tube with aluminium fin	-	30RB192~802
Super Enviro shield MCHX coils	263	E-coated MCHX coils	Improved corrosion resistance, recommended for heavy marine and industrial environments	30RB192~802

Dimensions/Clearances

30RB 192~262 / 30RQ 202~232

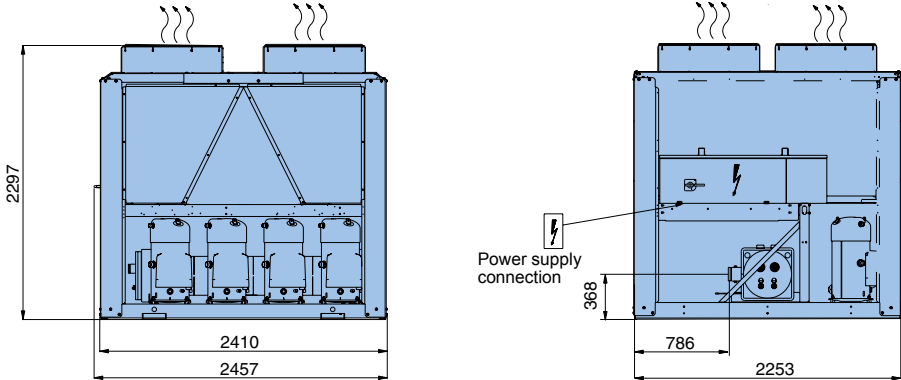

Standard unit with high pressure single pump hydronic module*

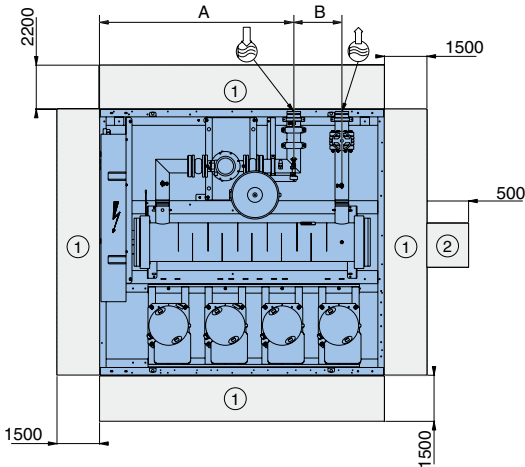

30RB	30RQ	A	B	C	D
192-262		1643	403	543	1503
	202-232	1643	393	543	1493

Unit without hydronic module

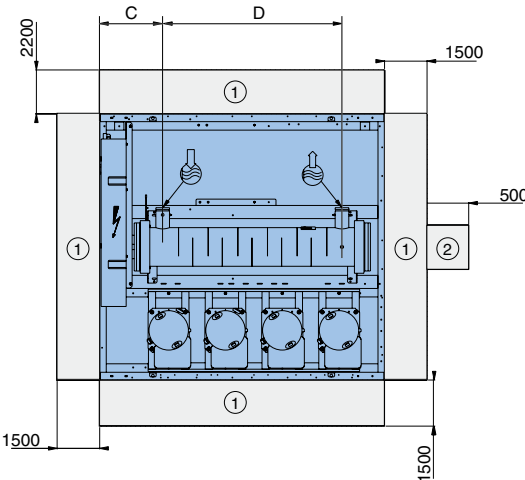

- ① Required clearances for maintenance and air flow
- ② Recommended space for evaporator tube removal
- Water inlet
- Water outlet
- Power supply connection
- Air outlet - do not obstruct

*Please contact local Carrier operation for other integrated hydronic module options

Dimensions/Clearances

30RB 342~522 / 30RQ 302~462

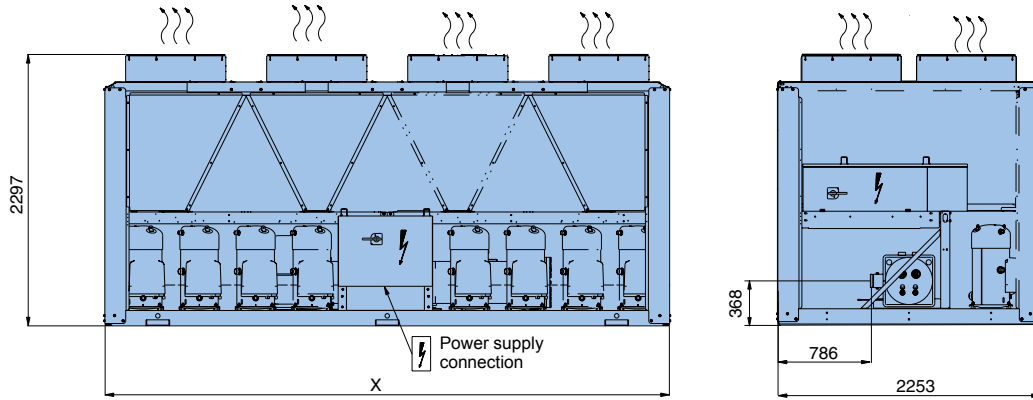

Standard unit with high pressure single pump hydronic module*

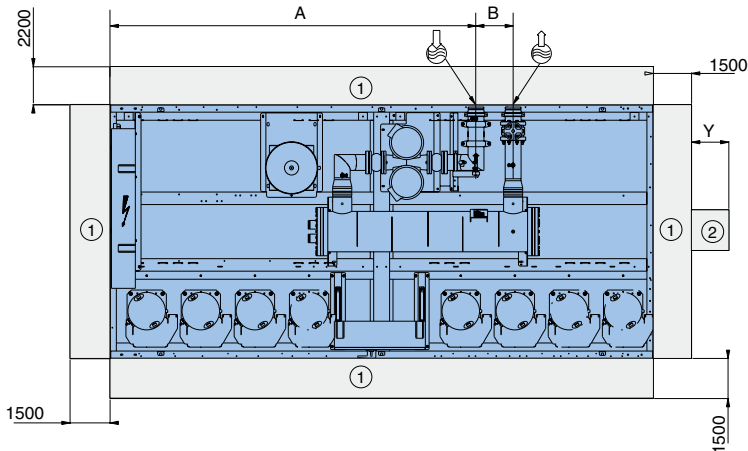

Unit without hydronic module

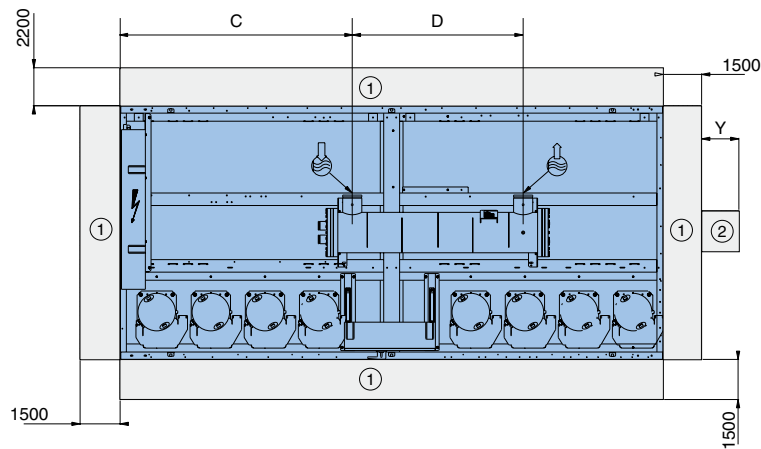

- ① Required clearances for maintenance and air flow
- ② Recommended space for evaporator tube removal
- Water inlet
- Water outlet
- Power supply connection
- Air outlet - do not obstruct

30RB	30RQ	A	B	C	D	X	Y
342~402		2746	323	1566	1503	3604	200
	522	3218	327	2042	1503	4798	0
	302	2745	314	1566	1493	3604	200
	372	2742	317	1566	1493	3604	200

*Please contact local Carrier operation for other integrated hydronic module options

Dimensions/Clearances

30RB 672~802

Standard unit without hydronic module

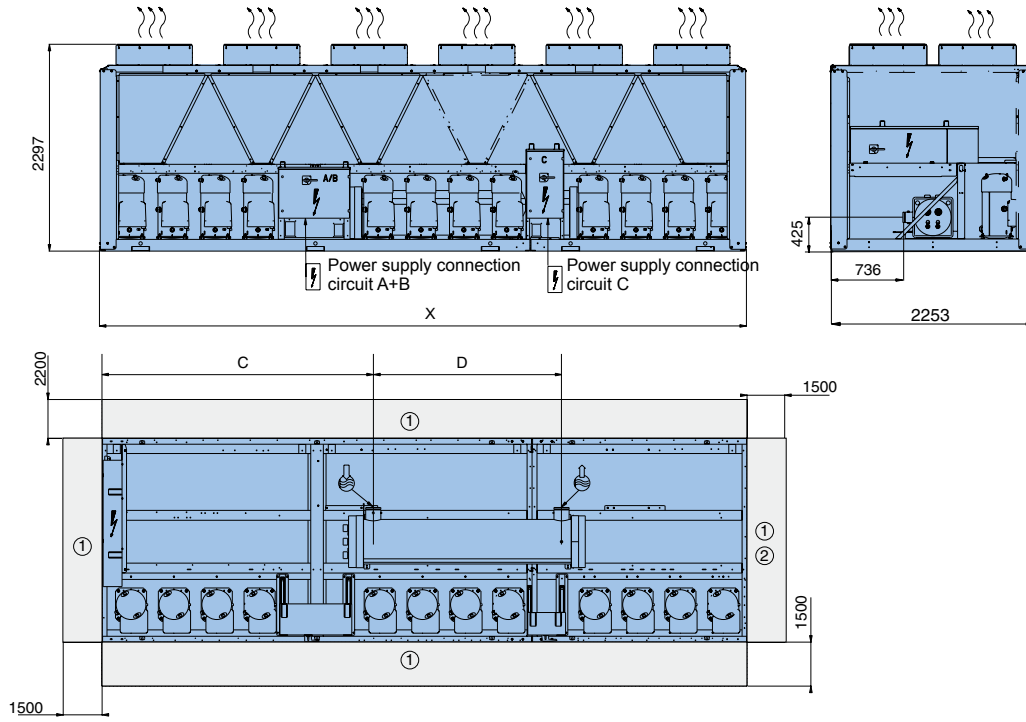

30RB	C	D	X
672PT116D	2532	2091	5992
802PT116D	3008	2091	7186

① Required clearances for maintenance and air flow

② Recommended space for evaporator tube removal

 Water inlet

 Water outlet

 Power supply connection

 Air outlet - do not obstruct

Multiple Chiller Installation

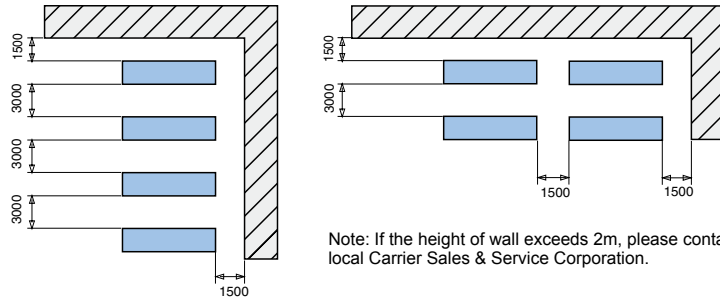

Note: If the height of wall exceeds 2m, please contact local Carrier Sales & Service Corporation.

Weight Distribution

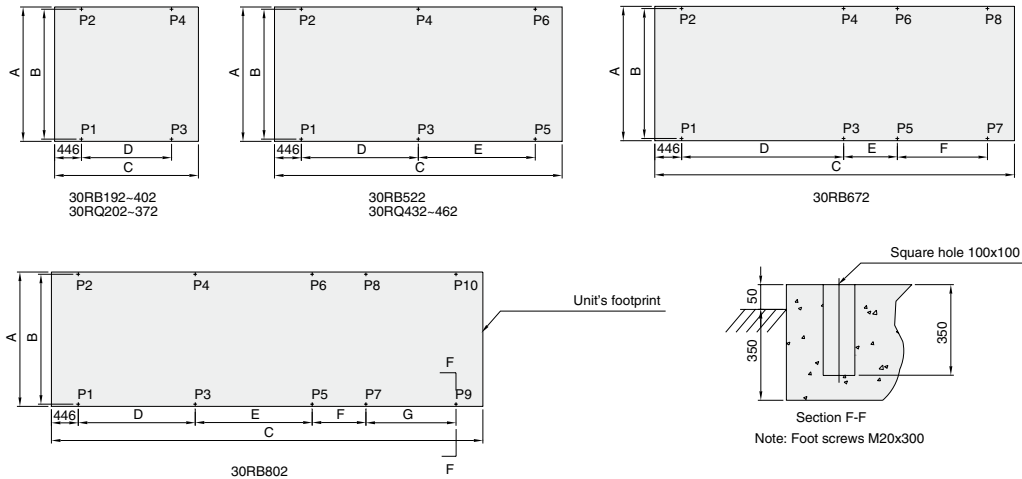

Models	Dimensions (mm)							Weight distribution (kg)										Operating weight
	A	B	C	D	E	F	G	P1	P2	P3	P4	P5	P6	P7	P8	P9	P10	
30RB192PT254	2231	2157	2388	1496				552	491	676	602							2320
30RB232PT254	2231	2157	2388	1496				503	631	530	666							2330
30RB262PT254	2231	2157	2388	1496				665	544	714	587							2510
30RB342PT254	2231	2157	3582	2690				927	769	888	736							3320
30RB402PT254	2231	2157	3582	2690				955	747	1036	812							3550
30RB522PT254	2231	2157	4776	1942	1942			677	543	1129	857	716	559					4480
30RB672PT116D/254	2231	2157	5970	2690	892	1496		944	744	840	634	840	633	559	445			5640
30RB802PT116D/254	2231	2157	7164	1942	1942	892	1496	519	386	1214	982	681	601	681	681	546	220	6510
30RQ202	2231	2157	2388	1496				579	518	702	628							2425
30RQ232	2231	2157	2388	1496				530	656	556	691							2431
30RQ302	2231	2157	3582	2690				901	755	865	724							3245
30RQ372	2231	2157	3582	2690				953	759	1029	819							3558
30RQ432	2231	2157	4776	1942	1942			648	526	1059	811	683	541					4268
30RQ462	2231	2157	4776	1942	1942			676	549	1106	847	713	565					4454

Hydronic Connections

Standard unit with integrated high pressure single pump hydronic module (except for 30RB 672/802)

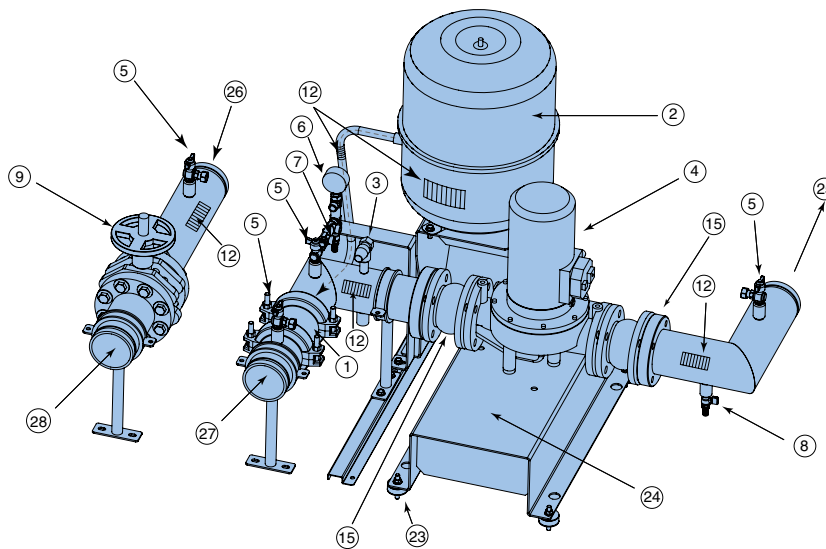
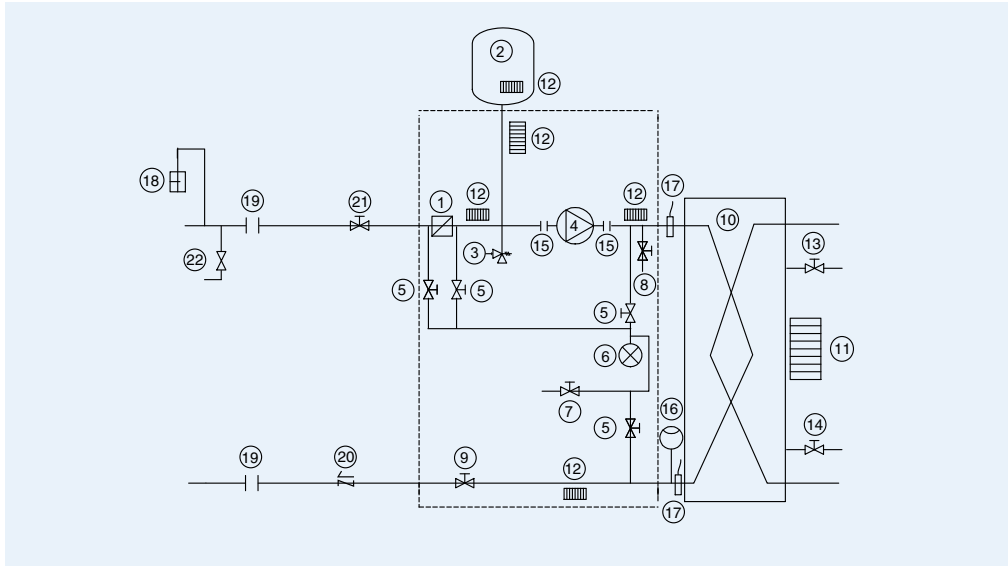

Legend:

Components of the unit and hydronic module

- | | |
|-----------------------------|-----------------------------------|
| 1. Victaulic screen filter | 10. Shell-and-tube heat exchanger |
| 2. Expansion tank | 11. Evaporator heater |
| 3. Safety valve | 12. Hydronic module heater |
| 4. Water pump | 13. Air vent (evaporator) |
| 5. Shut-off valve | 14. Water purge (evaporator) |
| 6. Pressure gauge | 15. Flexible connections |
| 7. Air vent | 16. Electronic flow switch |
| 8. Drain valve | 17. Water temperature sensor |
| 9. Water flow control valve | |

Installation components

- | |
|--------------------------|
| 18. Air vent |
| 19. Flexible connections |
| 20. Check valve |
| 21. Shut-off valve |
| 22. Water charge valve |
| 23. Anti-vibration pad |
| 24. Water pump support |

Water flow directions

- | |
|----------------------------------|
| 25. Evaporator water inlet |
| 26. Evaporator water outlet |
| 27. Hydronic module water inlet |
| 28. Hydronic module water outlet |

Evaporator Pressure Drop

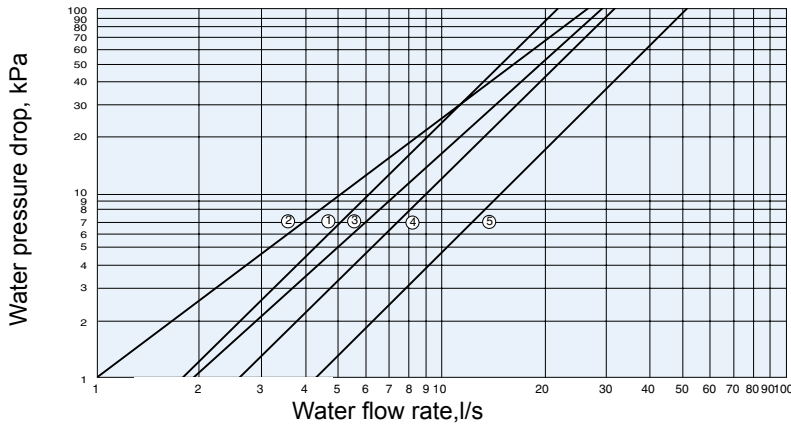

- 1 30RB 192
- 2 30RB 232 - 262 / 30RQ 202 - 302
- 3 30RB 342 - 402
- 4 30RB 522 / 30RQ 372 - 462
- 5 30RB 672 - 802

Available Static Pressure

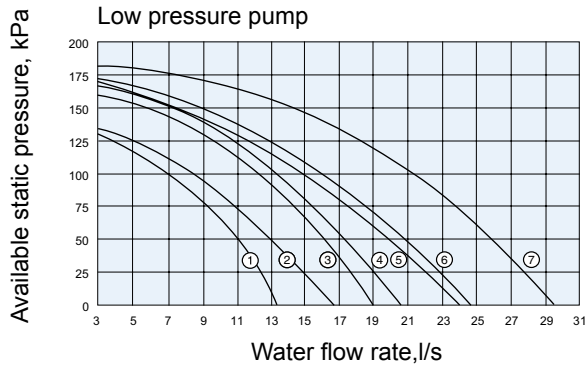

- 1 30RB 192 / 30RQ 202
- 2 30RB 232 - 262 / 30RQ 232
- 3 30RQ 302
- 4 30RB 342
- 5 30RB 402 / 30RQ 372
- 6 30RQ 432
- 7 30RB 522 / 30RQ 462

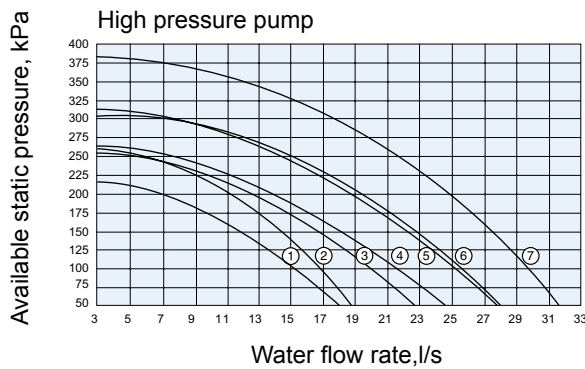

- 1 30RB 192 / 30RQ 202
- 2 30RB 232 - 262 / 30RQ 232
- 3 30RQ 302
- 4 30RB 342
- 5 30RB 402 / 30RQ 372
- 6 30RQ 432
- 7 30RB 522 / 30RQ 462

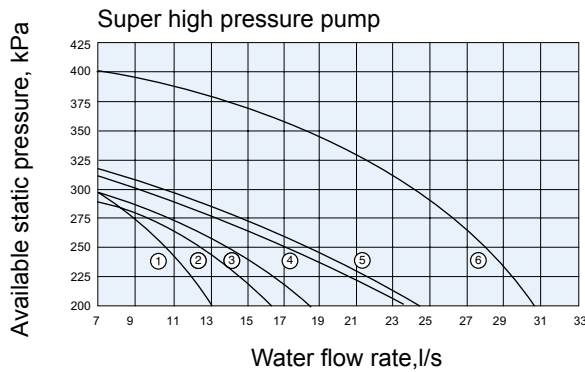

- 1 30RB 192 - 232 / 30RQ 202 - 232
- 2 30RB 262 / 30RQ 302
- 3 30RB 342
- 4 30RB 402
- 5 30RQ 372 / 30RQ 432
- 6 30RB 522 / 30RQ 462

Minimum Water Loop Volume

For better control of leaving water temperature, the water loop minimum capacity is given by the formula:

$$\text{Capacity} = \text{CAP (kW)} \times \text{N Liters}$$

Application		N
Normal air conditioning	30RB 192~802 / 30RQ 202~462	3.5
Process cooling	30RB 192~802 / 30RQ 202~462	6.5

Where Cap is the nominal system cooling capacity (kW) at the nominal operating conditions of the installation.

This volume is necessary for stable operation and accurate temperature control.

It is often necessary to add a buffer water tank to the circuit in order to achieve the required volume. The tank must be internally baffled in order to ensure proper mixing of the liquid (water or brine). Refer to the examples below.

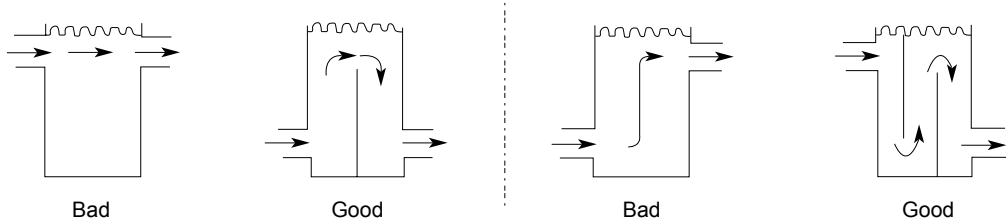

Field Control Wiring

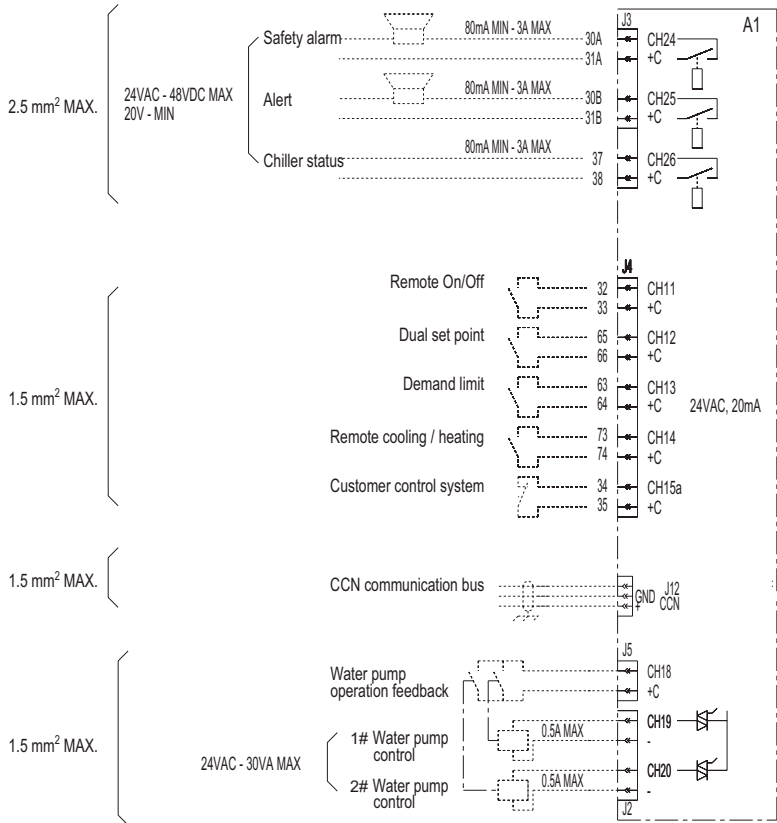

Carrier Corporation identified six specific areas of concentration that directly impact how we, as a world manufacturer, balance our customer' needs for comfort with the environment's needs for responsible consumption.

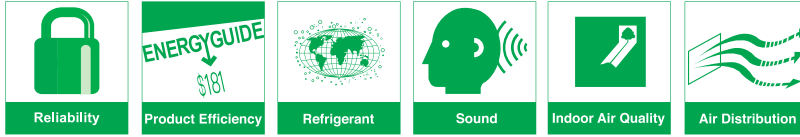

Welcome to Carrier Website
www.carrier.com.cn

